

Degrees of Freedom of the K User $M \times N$ MIMO Interference Channel

Tiangao Gou, Syed A. Jafar

Electrical Engineering and Computer Science

University of California Irvine, Irvine, California, 92697, USA

Email: {tgou,syed}@uci.edu

Abstract

We provide innerbound and outerbound for the total number of degrees of freedom of the K user multiple input multiple output (MIMO) Gaussian interference channel with M antennas at each transmitter and N antennas at each receiver if the channel coefficients are time-varying and drawn from a continuous distribution. The bounds are tight when the ratio $\frac{\max(M,N)}{\min(M,N)} = R$ is equal to an integer. For this case, we show that the total number of degrees of freedom is equal to $\min(M, N)K$ if $K \leq R$ and $\min(M, N)\frac{R}{R+1}K$ if $K > R$. Achievability is based on interference alignment. We also provide examples where using interference alignment combined with zero forcing can achieve more degrees of freedom than merely zero forcing for some MIMO interference channels with constant channel coefficients.

I. INTRODUCTION

Interference management is an important problem in wireless system design. Researchers have been exploring the capacity characterization of the Gaussian interference channel from an information theoretic perspective for more than thirty years. Several innerbounds and outerbounds of the capacity region for the two user Gaussian interference channel with single antenna nodes are determined [1]–[10]. However, the capacity region of the Gaussian interference channel remains an open problem in general. Interference channels with multiple-antenna nodes are studied in [11]–[13].

A. Motivating Example

In [13], the authors study the achievable rate region of the multiple input single output (MISO) interference channel obtained by treating interference as noise. They parameterize the Pareto boundary of the MISO Gaussian interference channel for arbitrary number of users and antennas at the transmitter as long as the number of antennas is larger than the number of users. For 2 user case, they show that the optimal beamforming directions are a linear combination of maximum ratio transmission vectors and the zero forcing vectors. However, for the case when the number of antennas is less than that of users, the optimal beamforming direction is not known. Intuitively, this is because when the number of antennas is less than that of users, it is not possible for each user to choose beamforming vectors to ensure no interference is created at all other users. The same problem is evident when we study this channel from a degrees of freedom¹ perspective. For the 2 user MISO interference channel with 2 transmit antennas and a single receive antenna, it is easy to see 2 degrees of freedom can be achieved if each user chooses zero forcing beamforming vector so that no interference is created at the other user. This is also the maximum number of degrees of freedom of this channel. However, for 3 user MISO interference channel with two antennas at each transmitter, it is not possible for each user to choose beamforming vectors so that no interference is created at all other users. As a result, only 2 degrees of freedom can be achieved by zero forcing. Can we do better than merely zero forcing? What is the total number of degrees of freedom of the 3 user MISO interference channel with 2 antennas at each transmitter? In general, what is the total number of degrees of freedom of the K user $M \times N$ MIMO interference channel? These are the questions that we explore in this paper.

Before we answer the above questions, let us first review the results on the degrees of freedom for the K user single input single output (SISO) Gaussian interference channel. If $K = 1$, it is well known the degrees of freedom for this point to point channel is 1. If $K = 2$, it is shown that this channel has only 1 degrees of freedom [14]. In other words, each user can achieve $\frac{1}{2}$ degrees of freedom simultaneously. For $K > 2$, it is surprising that every user is still able to achieve $\frac{1}{2}$ degrees of freedom no matter how large K is, if the channel coefficients are time-varying or frequency selective and drawn from a continuous distribution [16]. The achievable scheme is based on interference alignment combined with zero forcing.

For the MISO interference channel we find a similar characterization of the degrees of freedom. For example, the degrees of freedom for the 3 user MISO interference channel with 2 antennas at each transmitter is only 2 which is the same as that for the 2 user case. In other words, every user can achieve $\frac{2}{3}$ degrees of freedom simultaneously. For $K > 3$, every user is still able to achieve $\frac{2}{3}$ degrees of freedom regardless of K if the channel coefficients are

¹If the sum capacity can be expressed as $C_{\Sigma}(SNR) = \eta \log(SNR) + o(\log(SNR))$ then we say that the channel has η degrees of freedom.

time-varying or frequency selective and drawn from a continuous distribution. The achievable scheme is based on interference alignment on the single input multiple output (SIMO) interference channel for simplicity. If interference alignment is achieved on the SIMO channel it can also be achieved on the MISO channel, due to a reciprocity of alignment [19]. Interestingly, the interference alignment scheme is different from all prior schemes. All prior interference alignment schemes [16] (including the ones for the X channel [17], [18]) explicitly achieve one-to-one alignment of signal vectors, i.e., to minimize the dimension of the space spanned by interference signal vectors, one signal vector from an interferer and one signal vector from another interferer are aligned along the same dimension at the desired receivers. For example, consider 3 user SISO interference channel with 2 symbol extension or 3 user MIMO interference channel where each node has 2 antennas. We need to choose beamforming vectors $\mathbf{v}^{[2]}$ and $\mathbf{v}^{[3]}$ at Transmitter 2 and 3, respectively so that they cast overlapping shadow at Receiver 1, i.e.,

$$\mathbf{H}^{[12]}\mathbf{v}^{[2]} = \mathbf{H}^{[13]}\mathbf{v}^{[3]}$$

where $\mathbf{H}^{[12]}$ and $\mathbf{H}^{[13]}$ are 2×2 channel matrices from Transmitter 2 and 3 to Receiver 1, respectively. However, such an alignment is not feasible on the SIMO channel. Notice that the solution to the condition mentioned above exists only when the range of the two channel matrices has intersection. The channel matrix for 2 symbol extension SIMO channel with 2 antennas at each receiver is 4×2 . The range of two such channel matrices has null intersection with probability one if the channel coefficients are drawn from a continuous distribution. Thus, one-to-one interference alignment does not directly work for SIMO channel. Instead, interference from one interferer can only be aligned within the union of the spaces spanned by the interference vectors from R other interferers where R is the number of antennas at each receiver.

B. Overview of Results

In this paper we study the degrees of freedom of the K user MIMO Gaussian interference channel with M antennas at each transmitter and N antennas at each receiver. We provide both the innerbound (achievability) and outerbound (converse) of the total number of degrees of freedom for this channel. We show that $\min(M, N)K$ degrees of freedom can be achieved if $K \leq R$ and $\frac{R}{R+1} \min(M, N)K$ degrees of freedom can be achieved if $K > R$ where $R = \lfloor \frac{\max(M, N)}{\min(M, N)} \rfloor$. The total number of degrees of freedom is bounded above by $\min(M, N)K$ if $K \leq R$ and $\frac{\max(M, N)}{R+1}K$ if $K > R$. The bounds are tight when the ratio $\frac{\max(M, N)}{\min(M, N)} = R$ is equal to an integer which includes MISO and SIMO interference channel as special cases. The result indicates when $K \leq R$ every user can achieve $\min(M, N)$ degrees of freedom which is the same as what one can achieve without interference. When $K > R$ every user can achieve a fraction $\frac{R}{R+1}$ of the degrees of freedom that one can achieve in the absence of all interference. In other words, if $K \leq R$, then there is no loss of degrees of freedom for each user with interference. If $K > R$, every user only loses a fraction $\frac{1}{R+1}$ of the degrees of freedom that can be achieved without interference. In the second part of this paper we study the achievable degrees of freedom based on interference alignment scheme for the $R+2$ user MIMO interference channel with M antennas at each transmitter and RM , $R = 2, 3, \dots$ antennas at each receiver and constant channel coefficients, i.e. in the absence of time variation. We show that for this channel $RM + \lfloor \frac{RM}{R^2+2R-1} \rfloor$ degrees of freedom can be achieved without symbol extension. When $\lfloor \frac{RM}{R^2+2R-1} \rfloor < 0$ and hence $M < R+2$, $RM + \frac{1}{\lfloor \frac{R+2}{M} \rfloor}$ degrees of freedom per orthogonal dimension can be achieved with finite symbol extension. Since only RM degrees of freedom can be achieved using zero forcing, these results provide interesting examples where using interference alignment scheme can achieve more degrees of freedom than merely zero forcing.

II. SYSTEM MODEL

The K user MIMO interference channel is comprised of K transmitters and K receivers. Each transmitter has M antennas and each receiver has N antennas. The channel output at the k^{th} receiver over the t^{th} time slot is characterized by the following input-output relationship:

$$\mathbf{Y}^{[k]}(t) = \mathbf{H}^{[k1]}(t)\mathbf{X}^{[1]}(t) + \mathbf{H}^{[k2]}(t)\mathbf{X}^{[2]}(t) + \dots + \mathbf{H}^{[kK]}(t)\mathbf{X}^{[K]}(t) + \mathbf{Z}^{[k]}(t)$$

where, $k \in \{1, 2, \dots, K\}$ is the user index, $t \in \mathbb{N}$ is the time slot index, $\mathbf{Y}^{[k]}(t)$ is the $N \times 1$ output signal vector of the k^{th} receiver, $\mathbf{X}^{[j]}(t)$ is the $M \times 1$ input signal vector of the j^{th} transmitter, $\mathbf{H}^{[kj]}(t)$ is the $N \times M$ channel matrix from transmitter j to receiver k over the t^{th} time slot and $\mathbf{Z}^{[k]}(t)$ is $N \times 1$ additive white Gaussian noise (AWGN) vector at the k^{th} receiver. We assume all noise terms are i.i.d zero mean complex Gaussian with unit variance. We assume that all channel coefficient values are drawn i.i.d. from a continuous distribution and the absolute value of all the channel coefficients is bounded between a non-zero minimum value and a finite maximum value. The channel coefficient values vary at every channel use. Perfect knowledge of all channel coefficients is available to all transmitters and receivers.

Transmitters $1, 2, \dots, K$ have independent messages W_1, W_2, \dots, W_K intended for receivers $1, 2, \dots, K$, respectively. The total power across all transmitters is assumed to be equal to ρ . We indicate the size of the message set by $|W_i(\rho)|$. For codewords spanning t_0 channel uses, the rates $R_i(\rho) = \frac{\log |W_i(\rho)|}{t_0}$ are achievable if the probability of error for all messages can be simultaneously made arbitrarily small by choosing an appropriately large t_0 . The capacity region $\mathcal{C}(\rho)$ of the K user MIMO interference channel is the set of all achievable rate tuples $\mathbf{R}(\rho) = (R_1(\rho), R_2(\rho), \dots, R_K(\rho))$.

We define the spatial degrees of freedom as:

$$\eta \triangleq \lim_{\rho \rightarrow \infty} \frac{C_{\Sigma}(\rho)}{\log(\rho)} \quad (1)$$

where $C_{\Sigma}(\rho)$ is the sum capacity at SNR ρ .

III. OUTERBOUND ON THE DEGREES OF FREEDOM FOR THE K USER MIMO INTERFERENCE CHANNEL

We provide an outerbound on the degrees of freedom for the K user MIMO Gaussian interference channel in this section. Note that the converse holds for both time-varying and constant (non-zero) channel coefficients, i.e., time variations are not required. We present the result in the following theorem:

Theorem 1: For the K user MIMO Gaussian interference channel with M antennas at each transmitter and N antennas at each receiver, the total number of degrees of freedom is bounded above by $K \min(M, N)$ if $K \leq R$ and $\frac{\max(M, N)}{R+1}K$ if $K > R$ where $R = \lfloor \frac{\max(M, N)}{\min(M, N)} \rfloor$, i.e.

$$\eta = d_1 + \dots + d_K \leq \min(M, N)K \mathbf{1}(K \leq R) + \frac{\max(M, N)}{R+1}K \mathbf{1}(K > R)$$

where $\mathbf{1}(\cdot)$ is the indicator function and d_i represents the individual degrees of freedom achieved by user i .

Proof:

1) $K \leq R$: It is well known that the degrees of freedom of a single user MIMO Gaussian channel with M transmit antennas and N receive antennas is equal to $\min(M, N)$. Thus, for the K user MIMO Gaussian interference channel with the same antenna deployment, the degrees of freedom cannot be more than $K \min(M, N)$, i.e. $\eta \leq K \min(M, N)$.

2) $K > R$: Consider the $R + 1$ user MIMO interference channel with M, N antennas at the transmitter and receiver respectively. If we allow full cooperation among R transmitters and full cooperation among their corresponding receivers, then it is equivalent to the two user MIMO interference channel with RM, M (respectively) antennas at transmitters and RN, N antennas at their corresponding receivers. In [15], it is shown that the degrees of freedom for a two user MIMO Gaussian interference channel with M_1, M_2 antennas at transmitter 1, 2 and N_1, N_2 antennas at their corresponding receivers is $\min\{M_1 + M_2, N_1 + N_2, \max(M_1, N_2), \max(M_2, N_1)\}$. From this result, the degrees of freedom for the two user MIMO interference channel with RM, M antennas at the transmitters and RN, N at their corresponding receivers is $\max(M, N)$. Since allowing transmitters and receivers to cooperate does not hurt the capacity, the degrees of freedom of the original $R + 1$ user interference channel is no more than $\max(M, N)$. For $K > R + 1$ user case, picking any $R + 1$ users among K users gives an outerbound:

$$d_{i_1} + d_{i_2} + \dots + d_{i_{R+1}} \leq \max(M, N) \quad \forall i_1, \dots, i_{R+1} \in \{1, 2, \dots, K\}, \quad i_1 \neq i_2 \neq \dots \neq i_{R+1} \quad (2)$$

Adding up all such inequalities, we get the outerbound of the K user MIMO interference channel:

$$d_1 + d_2 + \dots + d_K \leq \frac{\max(M, N)}{R + 1} K \quad (3)$$

■

IV. INNERBOUND ON THE DEGREES OF FREEDOM FOR THE K USER MIMO INTERFERENCE CHANNEL

To derive the innerbound on the degrees of freedom for the K user MIMO Gaussian interference channel, we first obtain the achievable degrees of freedom for the K user SIMO interference channel with R antennas at each receiver. The innerbound on the degrees of freedom of the K user MIMO interference channel follows directly from the results of the SIMO interference channel. The corresponding input-output relationship of the K user SIMO interference channel is:

$$\mathbf{Y}^{[k]}(t) = \mathbf{h}^{[k1]}(t)x^{[1]}(t) + \mathbf{h}^{[k2]}(t)x^{[2]}(t) + \dots + \mathbf{h}^{[kK]}(t)x^{[K]}(t) + \mathbf{Z}^{[k]}(t)$$

where $\mathbf{Y}^{[k]}(t)$, $x^{[j]}(t)$, $\mathbf{h}^{[kj]}(t)$, $\mathbf{Z}^{[k]}(t)$ represent the channel output at receiver k , the channel input from transmitter j , the channel vector from transmitter j to receiver k and the AWGN vector at receiver k over the t^{th} time slot respectively.

We start with the problem mentioned in the introduction. For the 3 user SIMO Gaussian interference channel with 2 receive antennas, 2 degrees of freedom can be achieved using zero forcing. From the converse result in the last section, we cannot achieve more than 2 degrees of freedom on this channel. Therefore, the maximum number of degrees of freedom for this channel is 2. For the 4 user case, the converse result indicates that this channel cannot achieve more than $\frac{8}{3}$ degrees of freedom. Can we achieve this outerbound? Interestingly, using interference alignment scheme based on beamforming over multiple symbol extensions of the original channel, we are able to approach arbitrarily close to the outerbound. Consider the $\mu_n = 3(n + 1)^8$ symbol extension of the channel for any arbitrary $n \in \mathbb{N}$. Then, we effectively have a $2\mu_n \times \mu_n$ channel with a block diagonal structure. In order for each user to get exactly $\frac{2}{3}$ degrees of freedom per channel use and hence $\frac{2}{3}\mu_n = 2(n + 1)^8$ degrees of freedom on the μ_n symbol extension channel, each receiver with a total of $2\mu_n$ dimensional signal space should partition its signal space into two disjoint subspaces, one of which has $\frac{2}{3}\mu_n$ dimension for the desired signals and the other has $\frac{4}{3}\mu_n$ dimension for the interference signals. While such an alignment would exactly achieve the outerbound, it appears

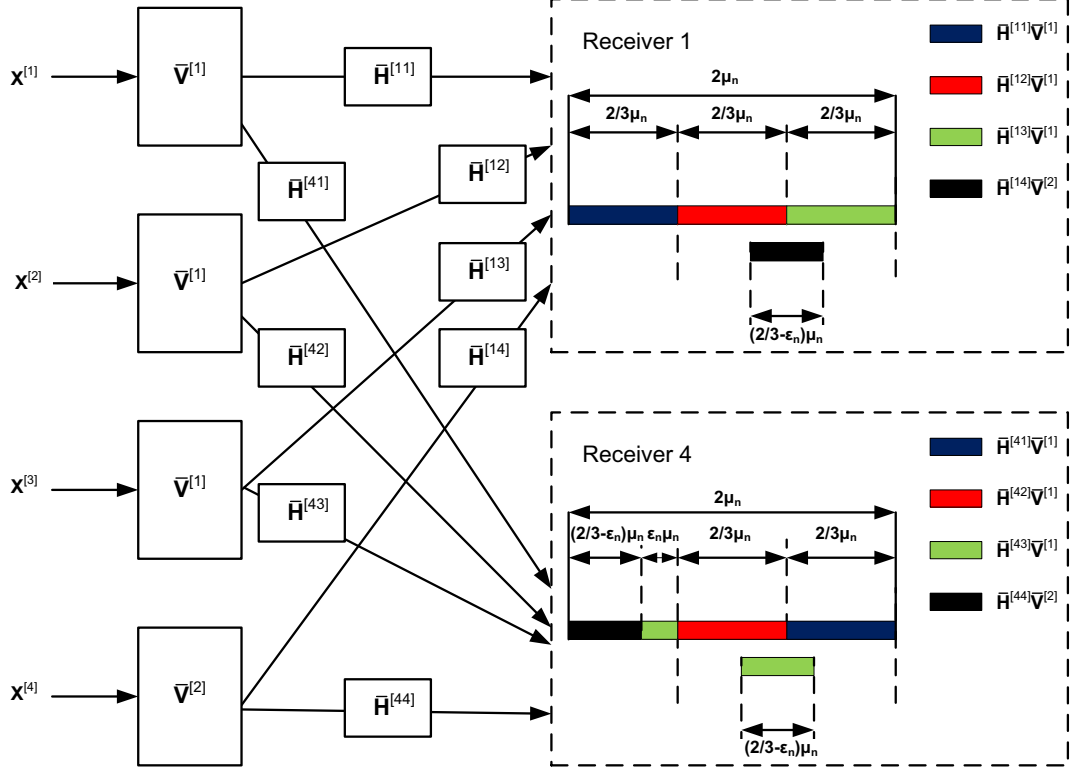

Fig. 1. Interference alignment on the 4 user interference channel

to be infeasible in general. But if we allow user 4 to achieve only $(\frac{2}{3} - \epsilon_n)\mu_n = 2n^8$ degrees of freedom over the μ_n extension channel where $\epsilon_n = \frac{2(n+1)^8 - 2n^8}{3(n+1)^8} = \frac{2}{3}[1 - \frac{1}{(1+\frac{1}{n})^8}]$, then it is possible for user 1, 2, 3 to achieve exactly $\frac{2}{3}\mu_n$ degrees of freedom simultaneously for a total of $(\frac{8}{3} - \epsilon_n)\mu_n$ degrees of freedom over the μ_n symbol extension channel. Hence, $\frac{8}{3} - \frac{2}{3}[1 - \frac{1}{(1+\frac{1}{n})^8}]$ degrees of freedom per channel use can be achieved. As $n \rightarrow \infty$, $\frac{2}{3}[1 - \frac{1}{(1+\frac{1}{n})^8}] \rightarrow 0$. Therefore, we can achieve arbitrarily close to the outerbound $\frac{8}{3}$. Next we present a detailed description of the interference-alignment scheme for the 4 user SIMO channel with 2 antennas at each receiver.

In the extended channel, Transmitter $j, \forall j = 1, 2, 3$ sends message W_j to Receiver j in the form of $\frac{2}{3}\mu_n$ independently encoded steams $x_m^{[j]}(t), m = 1, 2, \dots, \frac{2}{3}\mu_n$ along the same set of beamforming vectors $\bar{\mathbf{v}}_1^{[1]}(t), \dots, \bar{\mathbf{v}}_{\frac{2}{3}\mu_n}^{[1]}(t)$, each of dimension $\mu_n \times 1$, so that we have

$$\bar{\mathbf{X}}^{[j]}(t) = \sum_{m=1}^{\frac{2}{3}\mu_n} x_m^{[j]}(t)\bar{\mathbf{v}}_m^{[1]}(t) = \bar{\mathbf{V}}^{[1]}(t)\mathbf{X}^{[j]}(t), \quad j = 1, 2, 3$$

where $\bar{\mathbf{V}}^{[1]}(t) = [\bar{\mathbf{v}}_1^{[1]}(t), \dots, \bar{\mathbf{v}}_{\frac{2}{3}\mu_n}^{[1]}(t)]$ is a $\mu_n \times \frac{2}{3}\mu_n$ matrix and $\mathbf{X}^{[j]}(t)$ is a $\frac{2}{3}\mu_n \times 1$ column vector. Transmitter 4 sends message W_4 to Receiver 4 in the form of $(\frac{2}{3} - \epsilon_n)\mu_n$ independently encoded streams $x_m^{[4]}(t), m = 1, 2, \dots, (\frac{2}{3} - \epsilon_n)\mu_n$ along the beamforming vectors $\bar{\mathbf{v}}_1^{[2]}(t), \dots, \bar{\mathbf{v}}_{(\frac{2}{3} - \epsilon_n)\mu_n}^{[2]}(t)$ so that

$$\bar{\mathbf{X}}^{[4]}(t) = \sum_{m=1}^{(\frac{2}{3} - \epsilon_n)\mu_n} x_m^{[4]}(t)\bar{\mathbf{v}}_m^{[2]}(t) = \bar{\mathbf{V}}^{[2]}(t)\mathbf{X}^{[4]}(t)$$

where $\bar{\mathbf{V}}^{[2]}(t) = [\bar{\mathbf{v}}_1^{[2]}(t), \dots, \bar{\mathbf{v}}_{(\frac{2}{3}-\epsilon_n)\mu_n}^{[2]}(t)]$ is a $\mu_n \times (\frac{2}{3} - \epsilon_n)\mu_n$ matrix and $\mathbf{X}^{[4]}(t)$ is a $(\frac{2}{3} - \epsilon_n)\mu_n \times 1$ column vector. Therefore, the received signal at Receiver k is

$$\bar{\mathbf{Y}}^{[k]}(t) = \sum_{j=1}^3 \bar{\mathbf{H}}^{[kj]}(t) \bar{\mathbf{V}}^{[j]}(t) \mathbf{X}^{[j]}(t) + \bar{\mathbf{H}}^{[k4]}(t) \bar{\mathbf{V}}^{[2]}(t) \mathbf{X}^{[4]}(t) + \bar{\mathbf{Z}}^{[k]}(t)$$

where $\bar{\mathbf{H}}^{[kj]}(t)$ is the $2\mu_n \times \mu_n$ matrix representing the μ_n extension of the original channel matrix, i.e.

$$\bar{\mathbf{H}}^{[kj]}(t) = \begin{bmatrix} \mathbf{h}^{[kj]}(\mu_n(t-1)+1) & \mathbf{0} & \dots & \mathbf{0} \\ \mathbf{0} & \mathbf{h}^{[kj]}(\mu_n(t-1)+2) & \dots & \mathbf{0} \\ \vdots & \dots & \ddots & \vdots \\ \mathbf{0} & \mathbf{0} & \dots & \mathbf{h}^{[kj]}(\mu_n t) \end{bmatrix}$$

where $\mathbf{0}$ is a 2×1 vector with zero entries. Similarly, $\bar{\mathbf{Y}}$ and $\bar{\mathbf{Z}}$ represent the μ_n symbol extension of the \mathbf{Y} and \mathbf{Z} respectively. The interference alignment scheme is shown in Fig. 1. At Receiver 1, the interference from Transmitter 2 and Transmitter 3 cannot be aligned with each other because the subspaces spanned by the columns of $\bar{\mathbf{H}}^{[12]}$ and $\bar{\mathbf{H}}^{[13]}$ have null intersection with probability one. Thus, the interference vectors from Transmitter 2, i.e. columns of $\bar{\mathbf{H}}^{[12]} \bar{\mathbf{V}}^{[1]}$ and interference vectors from Transmitter 3, i.e. columns of $\bar{\mathbf{H}}^{[13]} \bar{\mathbf{V}}^{[1]}$ together span a $\frac{4}{3}\mu_n$ dimensional subspace in the $2\mu_n$ dimensional signal space at Receiver 1. In order for Receiver 1 to get a $\frac{2}{3}\mu_n$ dimensional interference-free signal space, we need to align the space spanned by the interference vectors from Transmitter 4, i.e. the range of $\bar{\mathbf{H}}^{[14]} \bar{\mathbf{V}}^{[2]}$ within the space spanned by the interference vectors from Transmitter 2 and 3. Note that we cannot align the interference from Transmitter 4 within the space spanned by the interference vectors from Transmitter 2 only or Transmitter 3 only. Because the subspaces spanned by the columns of $\bar{\mathbf{H}}^{[14]}$ and $\bar{\mathbf{H}}^{[12]}$ or the subspaces spanned by the columns of $\bar{\mathbf{H}}^{[14]}$ and $\bar{\mathbf{H}}^{[13]}$ have null intersection with probability one. Mathematically, we have

$$\text{span}(\bar{\mathbf{H}}^{[14]} \bar{\mathbf{V}}^{[2]}) \subset \text{span}([\bar{\mathbf{H}}^{[12]} \bar{\mathbf{V}}^{[1]} \quad \bar{\mathbf{H}}^{[13]} \bar{\mathbf{V}}^{[1]}]) \quad (4)$$

where $\text{span}(\mathbf{A})$ means the space spanned by the columns of matrix \mathbf{A} . This condition can be expressed equivalently as

$$\text{span}(\bar{\mathbf{H}}^{[14]} \bar{\mathbf{V}}^{[2]}) \subset \text{span}([\bar{\mathbf{H}}^{[12]} \quad \bar{\mathbf{H}}^{[13]}] \begin{bmatrix} \bar{\mathbf{V}}^{[1]} & \mathbf{0} \\ \mathbf{0} & \bar{\mathbf{V}}^{[1]} \end{bmatrix})$$

where $\mathbf{0}$ denotes a $\mu_n \times \frac{2}{3}\mu_n$ matrix with zero entries. Note that $[\bar{\mathbf{H}}^{[12]} \quad \bar{\mathbf{H}}^{[13]}]$ is a $2\mu_n \times 2\mu_n$ matrix with full rank almost surely. Therefore, the last equation is equivalent to

$$\text{span}(\underbrace{[\bar{\mathbf{H}}^{[12]} \quad \bar{\mathbf{H}}^{[13]}]^{-1} \bar{\mathbf{H}}^{[14]}}_{\mathbf{T}^{[1]}} \bar{\mathbf{V}}^{[2]}) \subset \text{span}(\begin{bmatrix} \bar{\mathbf{V}}^{[1]} & \mathbf{0} \\ \mathbf{0} & \bar{\mathbf{V}}^{[1]} \end{bmatrix}) \quad (5)$$

where $\mathbf{T}^{[1]}$ is a $2\mu_n \times \mu_n$ matrix which can be written in a block matrix form:

$$\mathbf{T}^{[1]} = \begin{bmatrix} \mathbf{T}_1^{[1]} \\ \mathbf{T}_2^{[1]} \end{bmatrix}$$

where $\mathbf{T}_1^{[1]}$ and $\mathbf{T}_2^{[1]}$ are $\mu_n \times \mu_n$ matrices. Therefore, (5) can be expressed alternatively as

$$\text{span}(\begin{bmatrix} \mathbf{T}_1^{[1]} \bar{\mathbf{V}}^{[2]} \\ \mathbf{T}_2^{[1]} \bar{\mathbf{V}}^{[2]} \end{bmatrix}) \subset \text{span}(\begin{bmatrix} \bar{\mathbf{V}}^{[1]} & \mathbf{0} \\ \mathbf{0} & \bar{\mathbf{V}}^{[1]} \end{bmatrix}) \quad (6)$$

This condition can be satisfied if

$$\begin{cases} \mathbf{T}_1^{[1]} \bar{\mathbf{V}}^{[2]} \prec \bar{\mathbf{V}}^{[1]} \\ \mathbf{T}_2^{[1]} \bar{\mathbf{V}}^{[2]} \prec \bar{\mathbf{V}}^{[1]} \end{cases} \quad (7)$$

where $\mathbf{P} \prec \mathbf{Q}$ means that the set of column vectors of matrix \mathbf{P} is a subset of the set of column vectors of matrix \mathbf{Q} .

Similarly, at Receiver 2, the interference vectors from Transmitter 4 are aligned within the space spanned by the interference vectors from Transmitter 1 and 3, i.e.,

$$\text{span}(\bar{\mathbf{H}}^{[24]} \bar{\mathbf{V}}^{[2]}) \subset \text{span}([\bar{\mathbf{H}}^{[21]} \bar{\mathbf{V}}^{[1]} \quad \bar{\mathbf{H}}^{[23]} \bar{\mathbf{V}}^{[1]}]) \quad (8)$$

This condition can be satisfied if

$$\begin{cases} \mathbf{T}_1^{[2]} \bar{\mathbf{V}}^{[2]} \prec \bar{\mathbf{V}}^{[1]} \\ \mathbf{T}_2^{[2]} \bar{\mathbf{V}}^{[2]} \prec \bar{\mathbf{V}}^{[1]} \end{cases} \quad (9)$$

where

$$\mathbf{T}^{[2]} = \begin{bmatrix} \mathbf{T}_1^{[2]} \\ \mathbf{T}_2^{[2]} \end{bmatrix} = [\bar{\mathbf{H}}^{[21]} \quad \bar{\mathbf{H}}^{[23]}]^{-1} \bar{\mathbf{H}}^{[24]}$$

At Receiver 3, the interference vectors from Transmitter 4 are aligned within the space spanned by the interference vectors from Transmitter 1 and 2, i.e.

$$\text{span}(\bar{\mathbf{H}}^{[34]} \bar{\mathbf{V}}^{[2]}) \subset \text{span}([\bar{\mathbf{H}}^{[31]} \bar{\mathbf{V}}^{[1]} \quad \bar{\mathbf{H}}^{[32]} \bar{\mathbf{V}}^{[1]}]) \quad (10)$$

This condition can be satisfied if

$$\begin{cases} \mathbf{T}_1^{[3]} \bar{\mathbf{V}}^{[2]} \prec \bar{\mathbf{V}}^{[1]} \\ \mathbf{T}_2^{[3]} \bar{\mathbf{V}}^{[2]} \prec \bar{\mathbf{V}}^{[1]} \end{cases} \quad (11)$$

where

$$\mathbf{T}^{[3]} = \begin{bmatrix} \mathbf{T}_1^{[3]} \\ \mathbf{T}_2^{[3]} \end{bmatrix} = [\bar{\mathbf{H}}^{[31]} \quad \bar{\mathbf{H}}^{[32]}]^{-1} \bar{\mathbf{H}}^{[34]}$$

Now, let us consider Receiver 4. As shown in Fig. 1, to get a $(\frac{2}{3} - \epsilon_n)\mu_n$ interference free dimensional signal space, the dimension of the space spanned by the interference vectors has to be less than or equal to $2\mu_n - (\frac{2}{3} - \epsilon_n)\mu_n$. To achieve this, we align the space spanned by $(\frac{2}{3} - \epsilon_n)\mu_n$ vectors of the interference vectors from Transmitter 3 within the space spanned by the interference from Transmitter 1 and 2. Since $\bar{\mathbf{V}}^{[1]}$ is a $\mu_n \times \frac{2}{3}\mu_n$ matrix, we can write it as $\bar{\mathbf{V}}^{[1]} = [\bar{\mathbf{V}}_u^{[1]} \quad \bar{\mathbf{V}}_{\epsilon_n}^{[1]}]$ where $\bar{\mathbf{V}}_u^{[1]}$ and $\bar{\mathbf{V}}_{\epsilon_n}^{[1]}$ are $\mu_n \times (\frac{2}{3} - \epsilon_n)\mu_n$ and $\mu_n \times \epsilon_n\mu_n$ matrices, respectively. We assume the space spanned by the columns of $\bar{\mathbf{H}}^{[43]} \bar{\mathbf{V}}_u^{[1]}$ is aligned within the space spanned by the interference from Transmitter 1 and 2, i.e.,

$$\text{span}(\bar{\mathbf{H}}^{[43]} \bar{\mathbf{V}}_u^{[1]}) \subset \text{span}([\bar{\mathbf{H}}^{[41]} \bar{\mathbf{V}}^{[1]} \quad \bar{\mathbf{H}}^{[42]} \bar{\mathbf{V}}^{[1]}]) \quad (12)$$

From equation (7), we have

$$\mathbf{T}_1^{[1]} \bar{\mathbf{V}}^{[2]} \prec \bar{\mathbf{V}}^{[1]}$$

This implies that $(\frac{2}{3} - \epsilon_n)\mu_n$ columns of $\bar{\mathbf{V}}^{[1]}$ are equal to the columns of $\mathbf{T}_1^{[1]}\bar{\mathbf{V}}^{[2]}$. Without loss of generality, we assume that $\bar{\mathbf{V}}_u^{[1]} = \mathbf{T}_1^{[1]}\bar{\mathbf{V}}^{[2]}$. Thus, (12) can be written as

$$\begin{aligned} \text{span}(\bar{\mathbf{H}}^{[43]}\bar{\mathbf{V}}_u^{[1]}) &= \text{span}(\bar{\mathbf{H}}^{[43]}\mathbf{T}_1^{[1]}\bar{\mathbf{V}}^{[2]}) \subset \text{span}([\bar{\mathbf{H}}^{[41]}\bar{\mathbf{V}}^{[1]} \quad \bar{\mathbf{H}}^{[42]}\bar{\mathbf{V}}^{[1]}]) \\ &\Rightarrow \text{span}(\bar{\mathbf{H}}^{[43]}\mathbf{T}_1^{[1]}\bar{\mathbf{V}}^{[2]}) \subset \text{span}\left([\bar{\mathbf{H}}^{[41]} \quad \bar{\mathbf{H}}^{[42]}] \begin{bmatrix} \bar{\mathbf{V}}^{[1]} & \mathbf{0} \\ \mathbf{0} & \bar{\mathbf{V}}^{[1]} \end{bmatrix}\right) \\ &\Rightarrow \text{span}\left(\underbrace{[\bar{\mathbf{H}}^{[41]} \quad \bar{\mathbf{H}}^{[42]}]^{-1} \bar{\mathbf{H}}^{[43]}\mathbf{T}_1^{[1]}}_{\mathbf{T}^{[4]}} \bar{\mathbf{V}}^{[2]}\right) \subset \text{span}\left(\begin{bmatrix} \bar{\mathbf{V}}^{[1]} & \mathbf{0} \\ \mathbf{0} & \bar{\mathbf{V}}^{[1]} \end{bmatrix}\right) \end{aligned}$$

Note that $\mathbf{T}^{[4]}$ is a $2\mu_n \times \mu_n$ matrix and can be written in a block matrix form:

$$\mathbf{T}^{[4]} = \begin{bmatrix} \mathbf{T}_1^{[4]} \\ \mathbf{T}_2^{[4]} \end{bmatrix}$$

where each block $\mathbf{T}_i^{[4]}$ is a $\mu_n \times \mu_n$ matrix. Then, the above equation can be expressed as

$$\text{span}\left(\begin{bmatrix} \mathbf{T}_1^{[4]}\bar{\mathbf{V}}^{[2]} \\ \mathbf{T}_2^{[4]}\bar{\mathbf{V}}^{[2]} \end{bmatrix}\right) \subset \text{span}\left(\begin{bmatrix} \bar{\mathbf{V}}^{[1]} & \mathbf{0} \\ \mathbf{0} & \bar{\mathbf{V}}^{[1]} \end{bmatrix}\right)$$

The above condition can be satisfied if

$$\begin{cases} \mathbf{T}_1^{[4]}\bar{\mathbf{V}}^{[2]} \prec \bar{\mathbf{V}}^{[1]} \\ \mathbf{T}_2^{[4]}\bar{\mathbf{V}}^{[2]} \prec \bar{\mathbf{V}}^{[1]} \end{cases} \quad (13)$$

Therefore, we need to design $\bar{\mathbf{V}}^{[1]}$ and $\bar{\mathbf{V}}^{[2]}$ to satisfy conditions (7), (9), (11), (13). Let \mathbf{w} be a $3(n+1)^8 \times 1$ column vector $\mathbf{w} = [1 \ 1 \ \dots \ 1]^T$. We need to choose $2(n+1)^8$ column vectors for $\bar{\mathbf{V}}^{[1]}$ and $2n^8$ column vectors for $\bar{\mathbf{V}}^{[2]}$. The sets of column vectors of $\bar{\mathbf{V}}^{[1]}$ and $\bar{\mathbf{V}}^{[2]}$ are chosen to be equal to the sets $\bar{V}^{[1]}$ and $\bar{V}^{[2]}$ where

$$\begin{aligned} \bar{V}^{[1]} &= \left\{ \left(\prod_{i=1,2j=1,\dots,4} (\mathbf{T}_i^{[j]})^{\alpha_i^{[j]}} \right) \mathbf{w} : \alpha_i^{[j]} \in \{1, \dots, n+1\} \right\} \cup \left\{ \left(\prod_{i=1,2j=1,\dots,4} (\mathbf{T}_i^{[j]})^{\beta_i^{[j]}} \right) \mathbf{w} : \beta_i^{[j]} \in \{n+2, \dots, 2n+2\} \right\} \\ \bar{V}^{[2]} &= \left\{ \left(\prod_{i=1,2j=1,\dots,4} (\mathbf{T}_i^{[j]})^{\alpha_i^{[j]}} \right) \mathbf{w} : \alpha_i^{[j]} \in \{1, \dots, n\} \right\} \cup \left\{ \left(\prod_{i=1,2j=1,\dots,4} (\mathbf{T}_i^{[j]})^{\beta_i^{[j]}} \right) \mathbf{w} : \beta_i^{[j]} \in \{n+2, \dots, 2n+1\} \right\} \end{aligned}$$

For example, when $n = 1$, the set $\bar{V}^{[2]}$ consists of two elements, i.e.,

$\bar{V}^{[2]} = \{(\prod_{i=1,2j=1,\dots,4} \mathbf{T}_i^{[j]})\mathbf{w} \quad (\prod_{i=1,2j=1,\dots,4} (\mathbf{T}_i^{[j]})^3)\mathbf{w}\}$. The set $\bar{V}^{[1]}$ consists of $2(1+1)^8 = 2^9$ column vectors in the form $\{(\prod_{i=1,2j=1,\dots,4} (\mathbf{T}_i^{[j]})^{\alpha_i^{[j]}})\mathbf{w} \quad (\prod_{i=1,2j=1,\dots,4} (\mathbf{T}_i^{[j]})^{\beta_i^{[j]}})\mathbf{w}\}$ where $\alpha_i^{[j]}$ takes values 1, 2; $\beta_i^{[j]}$ takes values 3, 4. Note that the above construction requires the commutative property of multiplication of matrices $\mathbf{T}_i^{[j]}$. Therefore, it requires $\mathbf{T}_i^{[j]}$ to be diagonal matrices. We provide the proof to show this is true in Appendix I. In order for each user to decode its desired message by zero forcing the interference, it is required that the desired signal vectors are linearly independent of the interference vectors. We also show this is true in Appendix I.

Remark: Note that for the K user Gaussian interference channel with single antenna nodes [16] and $M \times N$ user X channel [18], we need to construct two precoding matrices \mathbf{V} and \mathbf{V}' to satisfy several such conditions $\mathbf{V} \prec \mathbf{T}_i \mathbf{V}'$. Here, we use the same precoding matrix $\bar{\mathbf{V}}^{[1]}$ for Transmitter 1, 2, 3 so that we need to design two precoding matrices $\bar{\mathbf{V}}^{[1]}$ and $\bar{\mathbf{V}}^{[2]}$ to satisfy similar conditions $\bar{\mathbf{V}}^{[2]} \prec \mathbf{T}_i \bar{\mathbf{V}}^{[1]}$. Therefore, we use the same method in [16] and [18] to design $\bar{\mathbf{V}}^{[1]}$ and $\bar{\mathbf{V}}^{[2]}$ here.

We present the general result for the achievable degrees of freedom of the SIMO Gaussian interference channel in the following theorem.

Theorem 2: For the $K > R + 1$ user SIMO Gaussian interference channel with a single antenna at each transmitter and R antennas at each receiver, a total of $\frac{R}{R+1}K$ degrees of freedom per orthogonal time dimension can be achieved.

Proof: We provide the proof in Appendix I. ■

Next, we present the innerbound on the degrees of freedom for the K user MIMO Gaussian interference channel in the following theorem:

Theorem 3: For the time-varying K user MIMO Gaussian interference channel with channel coefficients drawn from a continuous distribution and M antennas at each transmitter and N antennas at each receiver, $K \min(M, N)$ degrees of freedom can be achieved if $K \leq R$ and $\frac{R}{R+1} \min(M, N)K$ degrees of freedom can be achieved if $K > R$ where $R = \lfloor \frac{\max(M, N)}{\min(M, N)} \rfloor$, i.e.

$$\eta = d_1 + \dots + d_K \geq \min(M, N)K \mathbb{1}(K \leq R) + \frac{R}{R+1} \min(M, N)K \mathbb{1}(K > R)$$

where $\mathbb{1}(\cdot)$ is the indicator function and d_i represents the individual degrees of freedom achieved by user i .

Proof: When $K \leq R$, the achievable scheme is based on beamforming and zero forcing. There is a reciprocity of such scheme discussed in [18]. It is shown that the degrees of freedom is unaffected if all transmitters and receivers are switched. For example, the degrees of freedom of the 2 user MISO interference channel with 2 transmit antennas and a single receive antenna is the same as that of the 2 user SIMO interference channel with a single transmit antenna and 2 receive antennas. When $K > R$, the achievable scheme is based on interference alignment. There is a reciprocity of alignment which shows that if interference alignment is feasible on the original channel then it is also feasible on the reciprocal channel [19]. Therefore, without loss of generality, we assume that the number of transmit antennas is less than or equal to that of receive antennas, i.e. $M \leq N$. As a result, we need to show that KM degrees of freedom can be achieved if $K \leq R$ and $\frac{R}{R+1}MK$ degrees of freedom can be achieved if $K > R$ where $R = \lfloor \frac{N}{M} \rfloor$. The case when $R = 1$ is solved in [16]. Therefore, we only consider the cases when $R > 1$ here.

1) $K \leq R$: Each transmitter sends M independent data streams along beamforming vectors. Each receiver gets M interference free streams by zero forcing the interference from unintended transmitters. As a result, each user can achieve M degrees of freedom for a total of KM degrees of freedom.

2) $K > R$: When $K = R + 1$, by discarding one user, we have a R user interference channel. RM degrees of freedom can be achieved on this channel using the achievable scheme described above. When $K > R + 1$, first we get RM antennas receive nodes by discarding $N - RM$ antennas at each receiver. Then, suppose we view each user with M antennas at the transmitter and RM antennas at the receiver as M different users each of which has a single transmit antenna and R receive antennas. Then, instead of a K user MIMO interference channel we obtain a KM user SIMO interference channel with R antennas at each receiver. By the result of Theorem 2, $\frac{R}{R+1}KM$ degrees of freedom can be achieved on this interference channel. Thus, we can also achieve $\frac{R}{R+1}KM$ degrees of freedom on the K user MIMO interference channel with time-varying channel coefficients. ■

Finally, we show that the innerbound and outerbound are tight when the ratio $\frac{\max(M, N)}{\min(M, N)}$ is equal to an integer. We present the result in the following corollary.

Corollary 1: For the time-varying K user MIMO Gaussian interference channel with M transmit antennas and N receive antennas, the total number of degrees of freedom is equal to $K \min(M, N)$ if $K \leq R$ and $\frac{R}{R+1} \min(M, N)K$

if $K > R$ when $R = \frac{\max(M,N)}{\min(M,N)}$ is equal to an integer, i.e.

$$\eta = d_1 + \dots + d_K = \min(M, N)K \mathbf{1}(K \leq R) + \frac{R}{R+1} \min(M, N)K \mathbf{1}(K > R)$$

Proof: The proof is obtained by directly verifying that the innerbound and outerbound match when the ratio $R = \frac{\max(M,N)}{\min(M,N)}$ is equal to an integer. When $K \leq R$, the innerbound and outerbound always match which is $\min(M, N)K$. When $K > R$, the innerbound and outerbound match when $\frac{R}{R+1} \min(M, N)K = \frac{\max(M,N)}{R+1}K$ which implies that $R \min(M, N) = \max(M, N)$. In other words, when either the number of transmit antennas is an integer multiple of that of receive antennas or vice versa, the total number of degrees of freedom is equal to $\frac{R}{R+1} \min(M, N)K$. ■

Remark: For the K user MIMO Gaussian interference channel with M, N antennas at the transmitter and the receiver respectively, if $K \leq R$ where $R = \lfloor \frac{\max(M,N)}{\min(M,N)} \rfloor$ then the total number of degrees of freedom is $\min(M, N)K$. This result can be extended to the same channel with constant channel coefficients.

Remark: If $\min(M, N) = 1$, then Corollary 1 shows that the total number of degrees of freedom of the K user SIMO Gaussian interference channel with R receive antennas or the K user MISO Gaussian interference channel with R transmit antennas is equal to $K \mathbf{1}(K \leq R) + \frac{R}{R+1}K \mathbf{1}(K > R)$.

V. ACHIEVABLE DEGREES OF FREEDOM FOR THE MIMO INTERFERENCE CHANNEL WITH CONSTANT CHANNEL COEFFICIENTS

Note that the converse results and the results of the achievable degrees of freedom based on merely zero forcing in previous sections are also applicable to the same channel with constant channel coefficients. The results of the achievable degrees of freedom based on interference alignment are obtained under the assumption that the channel coefficients are time-varying. It is not known if the results can be extended to the same channel with constant channel coefficients. Because the construction of precoding matrices $\bar{\mathbf{V}}^{[1]}$ and $\bar{\mathbf{V}}^{[2]}$ requires commutative property of multiplication of diagonal matrices $\mathbf{T}_i^{[j]}$. But for the MIMO scenarios, those matrices are not diagonal and commutative property cannot be exploited. In fact, the degrees of freedom for the interference channel with constant channel coefficients remains an open problem for more than 2 users. One known scenario is the 3 user MIMO Gaussian interference channel with M antennas at each node. In [16], it is shown that the total number of degrees of freedom is $\frac{3}{2}M$. The achievable scheme is based on interference alignment on signal vectors. In [20], the first known example of a K user Gaussian interference channel with single antenna nodes and constant channel coefficients are provided to achieve the outerbound on the degrees of freedom. The achievable scheme is based on interference alignment on signal levels rather than signal vectors. In this section, we will provide examples where interference alignment combined with zero forcing can achieve more degrees of freedom than merely zero-forcing for some MIMO Gaussian interference channels with constant channel coefficients. More general results are provided in Appendix II.

Example 1: Consider the 4 user MIMO Gaussian interference channel with 4 antennas at each transmitter and 8 antennas at each receiver. Note that for the 3 user MIMO interference channel with the same antenna deployment, the total number of degrees of freedom is 8. Also, for the 4 user case, only 8 degrees of freedom can be achieved by merely zero forcing. However, we will show that using interference alignment combined with zero forcing, 9 degrees of freedom can be achieved on this interference channel without channel extension. In other words, the 4 user MIMO interference channel with 4, 8 antennas at each transmitter and receiver respectively can achieve more

degrees of freedom than the 3 user interference channel with the same antenna deployment. Besides, more degrees of freedom can be achieved on this 4 user interference channel by using interference alignment combined with zero forcing than merely zero forcing. Next, we show that user 1, 2, 3 can achieve $d_i = 2, \forall i = 1, 2, 3$ degrees of freedom and user 4 can achieve $d_4 = 3$ degrees of freedom resulting in a total of 9 degrees of freedom achieved on this channel. Transmitter i sends message W_i to Receiver i using d_i independently encoded streams along vectors $\mathbf{v}_m^{[i]}$, i.e.,

$$\begin{aligned}\mathbf{X}^{[i]} &= \sum_{m=1}^2 x_m^{[i]} \mathbf{v}_m^{[i]} = \mathbf{V}^{[i]} \mathbf{X}^i, \quad i = 1, 2, 3 \\ \mathbf{X}^{[4]} &= \sum_{m=1}^3 x_m^{[4]} \mathbf{v}_m^{[4]} = \mathbf{V}^{[4]} \mathbf{X}^4\end{aligned}$$

where $\mathbf{V}^{[i]} = [\mathbf{v}_1^{[i]} \quad \mathbf{v}_2^{[i]}], i = 1, 2, 3$ and $\mathbf{V}^{[4]} = [\mathbf{v}_1^{[4]} \quad \mathbf{v}_2^{[4]} \quad \mathbf{v}_3^{[4]}]$. The signal at Receiver j can be written as

$$\mathbf{Y}^{[j]} = \sum_{i=1}^4 \mathbf{H}^{[ji]} \mathbf{V}^{[i]} \mathbf{X}^i + \mathbf{Z}^{[j]}.$$

In order for each receiver to decode its message by zero forcing the interference signals, the dimension of the space spanned by the interference signal vectors has to be less than or equal to $8 - d_i$. Since there are $9 - d_i$ interference vectors at receiver i , we need to align $(9 - d_i) - (8 - d_i) = 1$ interference signal vector at each receiver. This can be achieved by if one interference vector lies in the space spanned by other interference vectors at each receiver. Mathematically, we choose the following alignments

$$\begin{aligned}\text{span}(\mathbf{H}^{[14]} \mathbf{v}_1^{[4]}) \subset \text{span}([\mathbf{H}^{[12]} \mathbf{V}^{[2]} \quad \mathbf{H}^{[13]} \mathbf{V}^{[3]}]) &\Rightarrow \text{span}(\underbrace{[\mathbf{H}^{[12]} \quad \mathbf{H}^{[13]}]^{-1} \mathbf{H}^{[14]} \mathbf{v}_1^{[4]}}_{\mathbf{T}^{[1]}}) \subset \text{span}\left(\begin{bmatrix} \mathbf{V}^{[2]} & \mathbf{0} \\ \mathbf{0} & \mathbf{V}^{[3]} \end{bmatrix}\right) \\ &\Rightarrow \text{span}\left(\begin{bmatrix} \mathbf{T}_1^{[1]} \mathbf{v}_1^{[4]} \\ \mathbf{T}_2^{[1]} \mathbf{v}_1^{[4]} \end{bmatrix}\right) \subset \text{span}\left(\begin{bmatrix} \mathbf{V}^{[2]} & \mathbf{0} \\ \mathbf{0} & \mathbf{V}^{[3]} \end{bmatrix}\right)\end{aligned}\quad (14)$$

$$\begin{aligned}\text{span}(\mathbf{H}^{[24]} \mathbf{v}_1^{[4]}) \subset \text{span}([\mathbf{H}^{[21]} \mathbf{V}^{[1]} \quad \mathbf{H}^{[23]} \mathbf{V}^{[3]}]) &\Rightarrow \text{span}(\underbrace{[\mathbf{H}^{[21]} \quad \mathbf{H}^{[23]}]^{-1} \mathbf{H}^{[24]} \mathbf{v}_1^{[4]}}_{\mathbf{T}^{[2]}}) \subset \text{span}\left(\begin{bmatrix} \mathbf{V}^{[1]} & \mathbf{0} \\ \mathbf{0} & \mathbf{V}^{[3]} \end{bmatrix}\right) \\ &\Rightarrow \text{span}\left(\begin{bmatrix} \mathbf{T}_1^{[2]} \mathbf{v}_1^{[4]} \\ \mathbf{T}_2^{[2]} \mathbf{v}_1^{[4]} \end{bmatrix}\right) \subset \text{span}\left(\begin{bmatrix} \mathbf{V}^{[1]} & \mathbf{0} \\ \mathbf{0} & \mathbf{V}^{[3]} \end{bmatrix}\right)\end{aligned}\quad (15)$$

$$\begin{aligned}\text{span}(\mathbf{H}^{[32]} \mathbf{v}_1^{[2]}) \subset \text{span}([\mathbf{H}^{[31]} \mathbf{V}^{[1]} \quad \mathbf{H}^{[34]} \mathbf{V}^{[4]}]) &\Rightarrow \text{span}(\underbrace{[\mathbf{H}^{[31]} \quad \mathbf{H}^{[34]}]^{-1} \mathbf{H}^{[32]} \mathbf{v}_1^{[2]}}_{\mathbf{T}^{[3]}}) \subset \text{span}\left(\begin{bmatrix} \mathbf{V}^{[1]} & \mathbf{0} \\ \mathbf{0} & \mathbf{V}^{[4]} \end{bmatrix}\right) \\ &\Rightarrow \text{span}\left(\begin{bmatrix} \mathbf{T}_1^{[3]} \mathbf{v}_1^{[2]} \\ \mathbf{T}_2^{[3]} \mathbf{v}_1^{[2]} \end{bmatrix}\right) \subset \text{span}\left(\begin{bmatrix} \mathbf{V}^{[1]} & \mathbf{0} \\ \mathbf{0} & \mathbf{V}^{[4]} \end{bmatrix}\right)\end{aligned}\quad (16)$$

$$\begin{aligned}\text{span}(\mathbf{H}^{[41]} \mathbf{v}_1^{[1]}) \subset \text{span}([\mathbf{H}^{[42]} \mathbf{V}^{[2]} \quad \mathbf{H}^{[43]} \mathbf{V}^{[3]}]) &\Rightarrow \text{span}(\underbrace{[\mathbf{H}^{[42]} \quad \mathbf{H}^{[43]}]^{-1} \mathbf{H}^{[41]} \mathbf{v}_1^{[1]}}_{\mathbf{T}^{[4]}}) \subset \text{span}\left(\begin{bmatrix} \mathbf{V}^{[2]} & \mathbf{0} \\ \mathbf{0} & \mathbf{V}^{[3]} \end{bmatrix}\right) \\ &\Rightarrow \text{span}\left(\begin{bmatrix} \mathbf{T}_1^{[4]} \mathbf{v}_1^{[1]} \\ \mathbf{T}_2^{[4]} \mathbf{v}_1^{[1]} \end{bmatrix}\right) \subset \text{span}\left(\begin{bmatrix} \mathbf{V}^{[2]} & \mathbf{0} \\ \mathbf{0} & \mathbf{V}^{[3]} \end{bmatrix}\right)\end{aligned}\quad (17)$$

where $\mathbf{T}^{[i]}$ is an 8×4 matrix which can be written in a block matrix form:

$$\mathbf{T}^{[i]} = \begin{bmatrix} \mathbf{T}_1^{[i]} \\ \mathbf{T}_2^{[i]} \end{bmatrix} \quad i = 1, 2, 3, 4 \quad (18)$$

where $\mathbf{T}_1^{[i]}$ and $\mathbf{T}_2^{[i]}$ are 4×4 matrices. To satisfy the conditions (14), (15), (16), (17), we let

$$\begin{aligned} \mathbf{T}_1^{[1]} \mathbf{v}_1^{[4]} &= \mathbf{v}_1^{[2]} & \text{span}(\mathbf{T}_2^{[1]} \mathbf{v}_1^{[4]}) &= \text{span}(\mathbf{v}_1^{[3]}) \\ \mathbf{T}_1^{[2]} \mathbf{v}_1^{[4]} &= \mathbf{v}_1^{[1]} & \text{span}(\mathbf{T}_2^{[2]} \mathbf{v}_1^{[4]}) &= \text{span}(\mathbf{v}_1^{[3]}) \\ \mathbf{T}_1^{[3]} \mathbf{v}_1^{[2]} &= \mathbf{v}_2^{[1]} & \mathbf{T}_2^{[3]} \mathbf{v}_1^{[2]} &= \mathbf{v}_2^{[4]} \\ \mathbf{T}_1^{[4]} \mathbf{v}_1^{[1]} &= \mathbf{v}_2^{[2]} & \mathbf{T}_2^{[4]} \mathbf{v}_1^{[1]} &= \mathbf{v}_2^{[3]} \end{aligned}$$

Notice once $\mathbf{v}_1^{[4]}$ is chosen, all other vectors can be solved from the above equations. To solve $\mathbf{v}_1^{[4]}$, we have

$$\begin{aligned} \text{span}(\mathbf{T}_1^{[1]} \mathbf{v}_1^{[4]}) &= \text{span}(\mathbf{T}_2^{[2]} \mathbf{v}_1^{[4]}) \\ \Rightarrow \text{span}((\mathbf{T}_2^{[2]})^{-1} \mathbf{T}_1^{[1]} \mathbf{v}_1^{[4]}) &= \text{span}(\mathbf{v}_1^{[4]}) \\ \Rightarrow \mathbf{v}_1^{[4]} &= \mathbf{e}, \end{aligned}$$

where \mathbf{e} is an eigenvector of matrix $(\mathbf{T}_2^{[2]})^{-1} \mathbf{T}_1^{[1]}$. Note that the above construction only specifies $\mathbf{V}^{[i]}, \forall i = 1, 2, 3$ and $\mathbf{v}_1^{[4]}, \mathbf{v}_2^{[4]}$. The remaining $\mathbf{v}_3^{[4]}$ can be picked randomly according to a continuous distribution so that all columns of $\mathbf{V}^{[i]}$ are linearly independent.

Through interference alignment, we ensure that the interference vectors span a small enough signal space. We need to verify that the desired signal vectors, i.e., $\mathbf{H}^{[ii]} \mathbf{V}^{[i]}$ are linearly independent of interference vectors so that each receiver can decode its message using zero forcing. Notice that the direct channel matrices $\mathbf{H}^{[ii]}, i = 1, 2, 3, 4$ do not appear in the interference alignment equations, $\mathbf{V}^{[i]}$ undergoes an independent linear transformation by multiplying $\mathbf{H}^{[ii]}$. Therefore, at each receiver the desired signal vectors are linearly independent of the interference signal vectors with probability one. As a result, user i can achieve d_i degrees of freedom and a total of 9 degrees of freedom can be achieved.

Example 2: Consider the 4 user MIMO Gaussian interference channel with 2 antennas at each transmitter and 4 antennas at each receiver. We show that 9 degrees of freedom can be achieved on the 2-symbol extension of the original channel and hence $4\frac{1}{2}$ degrees of freedom per channel use can be achieved. Since only 4 degrees of freedom can be achieved using merely zero forcing, $\frac{1}{2}$ more degrees of freedom is achieved using interference alignment scheme. Note that although we have equivalently a 4 user interference channel with 4×8 channel on the 2-symbol extension channel, we cannot use the same achievable scheme used in Example 1 due to the block diagonal structure of the extension channel matrix. Consider 2-symbol extension of the channel. The channel input-output relationship is

$$\bar{\mathbf{Y}}^{[j]} = \sum_{i=1}^4 \bar{\mathbf{H}}^{[ji]} \bar{\mathbf{X}}^{[i]} + \bar{\mathbf{Z}}^{[j]} \quad \forall j = 1, 2, 3, 4$$

where the overbar notation represents the 2-symbol extensions so that

$$\bar{\mathbf{X}} \triangleq \begin{bmatrix} \mathbf{X}(2t) \\ \mathbf{X}(2t+1) \end{bmatrix} \quad \bar{\mathbf{Z}} \triangleq \begin{bmatrix} \mathbf{Z}(2t) \\ \mathbf{Z}(2t+1) \end{bmatrix}$$

where \mathbf{X} and \mathbf{Z} are 2×1 and 4×1 vectors respectively, and

$$\bar{\mathbf{H}} \triangleq \begin{bmatrix} \mathbf{H} & \mathbf{0} \\ \mathbf{0} & \mathbf{H} \end{bmatrix}.$$

where \mathbf{H} is the 4×2 channel matrix. We assign $d_1 = d_2 = d_3 = 2$ and $d_4 = 3$ degrees of freedom to message W_1, W_2, W_3, W_4 respectively for a total 9 degrees of freedom over the 2-symbol extension channel. Transmitter i sends message W_i in the form of d_i independently encoded streams along the direction vectors $\bar{\mathbf{v}}_1^{[i]}, \dots, \bar{\mathbf{v}}_{d_i}^{[i]}$, each of dimension 4×1 , so that we have:

$$\bar{\mathbf{X}}^{[i]} = \sum_{m=1}^{d_i} \bar{\mathbf{v}}_m^{[i]} x_m^{[i]} = \bar{\mathbf{V}}^{[i]} \mathbf{X}^{[i]} \quad i = 1, 2, 3, 4$$

where $\bar{\mathbf{V}}^{[i]}$ and $\mathbf{X}^{[i]}$ are $4 \times d_i$ and $d_i \times 1$ matrices respectively. In order to get d_i interference free dimension at Receiver i , we need to align 1 interference vector at each receiver. This can be achieved if one interference vector lies in the space spanned by other interference vectors at each receiver. Mathematically, we choose the following alignments:

$$\text{span}(\bar{\mathbf{H}}^{[12]} \bar{\mathbf{v}}_1^{[2]}) \subset \text{span}(\underbrace{[\bar{\mathbf{H}}^{[13]} \bar{\mathbf{V}}^{[3]} \quad \bar{\mathbf{H}}^{[14]} \bar{\mathbf{V}}^{[4]}]}_{\mathbf{T}^{[1]}}) \Rightarrow \text{span}(\underbrace{[\bar{\mathbf{H}}^{[13]} \quad \bar{\mathbf{H}}^{[14]}]^{-1} \bar{\mathbf{H}}^{[12]} \bar{\mathbf{v}}_1^{[2]}}_{\mathbf{T}^{[1]}}) \subset \text{span} \left(\begin{bmatrix} \bar{\mathbf{V}}^{[3]} & \mathbf{0} \\ \mathbf{0} & \bar{\mathbf{V}}^{[4]} \end{bmatrix} \right) \quad (19)$$

$$\text{span}(\bar{\mathbf{H}}^{[23]} \bar{\mathbf{v}}_1^{[3]}) \subset \text{span}(\underbrace{[\bar{\mathbf{H}}^{[21]} \bar{\mathbf{V}}^{[1]} \quad \bar{\mathbf{H}}^{[24]} \bar{\mathbf{V}}^{[4]}]}_{\mathbf{T}^{[2]}}) \Rightarrow \text{span}(\underbrace{[\bar{\mathbf{H}}^{[21]} \quad \bar{\mathbf{H}}^{[24]}]^{-1} \bar{\mathbf{H}}^{[23]} \bar{\mathbf{v}}_1^{[3]}}_{\mathbf{T}^{[2]}}) \subset \text{span} \left(\begin{bmatrix} \bar{\mathbf{V}}^{[1]} & \mathbf{0} \\ \mathbf{0} & \bar{\mathbf{V}}^{[4]} \end{bmatrix} \right) \quad (20)$$

$$\text{span}(\bar{\mathbf{H}}^{[34]} \bar{\mathbf{v}}_1^{[4]}) \subset \text{span}(\underbrace{[\bar{\mathbf{H}}^{[31]} \bar{\mathbf{V}}^{[1]} \quad \bar{\mathbf{H}}^{[32]} \bar{\mathbf{V}}^{[2]}]}_{\mathbf{T}^{[3]}}) \Rightarrow \text{span}(\underbrace{[\bar{\mathbf{H}}^{[31]} \quad \bar{\mathbf{H}}^{[32]}]^{-1} \bar{\mathbf{H}}^{[34]} \bar{\mathbf{v}}_1^{[4]}}_{\mathbf{T}^{[3]}}) \subset \text{span} \left(\begin{bmatrix} \bar{\mathbf{V}}^{[1]} & \mathbf{0} \\ \mathbf{0} & \bar{\mathbf{V}}^{[2]} \end{bmatrix} \right) \quad (21)$$

$$\text{span}(\bar{\mathbf{H}}^{[41]} \bar{\mathbf{v}}_1^{[1]}) \subset \text{span}(\underbrace{[\bar{\mathbf{H}}^{[42]} \bar{\mathbf{V}}^{[2]} \quad \bar{\mathbf{H}}^{[43]} \bar{\mathbf{V}}^{[3]}]}_{\mathbf{T}^{[4]}}) \Rightarrow \text{span}(\underbrace{[\bar{\mathbf{H}}^{[42]} \quad \bar{\mathbf{H}}^{[43]}]^{-1} \bar{\mathbf{H}}^{[41]} \bar{\mathbf{v}}_1^{[1]}}_{\mathbf{T}^{[4]}}) \subset \text{span} \left(\begin{bmatrix} \bar{\mathbf{V}}^{[2]} & \mathbf{0} \\ \mathbf{0} & \bar{\mathbf{V}}^{[3]} \end{bmatrix} \right) \quad (22)$$

where $\mathbf{T}^{[i]}$ is the 8×4 matrix which can be written in a block matrix form:

$$\mathbf{T}^{[i]} = \begin{bmatrix} \mathbf{T}_1^{[i]} \\ \mathbf{T}_2^{[i]} \end{bmatrix} \quad i = 1, 2, 3, 4 \quad (23)$$

The above equations can be satisfied if

$$\mathbf{T}^{[1]} \bar{\mathbf{v}}_1^{[2]} = \begin{bmatrix} \bar{\mathbf{v}}_1^{[3]} \\ \bar{\mathbf{v}}_1^{[4]} \end{bmatrix} \quad \mathbf{T}^{[2]} \bar{\mathbf{v}}_1^{[3]} = \begin{bmatrix} \bar{\mathbf{v}}_1^{[1]} \\ \bar{\mathbf{v}}_2^{[4]} \end{bmatrix} \quad \mathbf{T}^{[3]} \bar{\mathbf{v}}_1^{[4]} = \begin{bmatrix} \bar{\mathbf{v}}_2^{[1]} \\ \bar{\mathbf{v}}_2^{[2]} \end{bmatrix} \quad \mathbf{T}^{[4]} \bar{\mathbf{v}}_1^{[1]} = \begin{bmatrix} \bar{\mathbf{v}}_3^{[2]} \\ \bar{\mathbf{v}}_2^{[3]} \end{bmatrix} \quad (24)$$

Notice that once we pick $\bar{\mathbf{v}}_1^{[2]}$, all other vectors can be solved from above equations. $\bar{\mathbf{v}}_1^{[2]}$ can be chosen randomly according to a continuous distribution so that all vectors are linearly independent with probability one. Also, since all the vectors are chosen independently of the direct channel matrices $\bar{\mathbf{H}}^{[ii]}$ and all entries of $\bar{\mathbf{V}}^{[i]}$ are not equal to zero almost surely, the desired signal vectors are linearly independent of the interference vectors at each receiver. As a result, Receiver i can decode its message by zero forcing the interference to achieve d_i degrees of freedom for a total of 9 degrees of freedom over the 2-symbol extension channel. Therefore, $4\frac{1}{2}$ degrees of freedom per channel use can be achieved on the original channel.

VI. CONCLUSION

We investigate the degrees of freedom for the K user MIMO Gaussian interference channel with M, N antennas at each transmitter and receiver, respectively. The motivation of this work is the potential benefits of interference alignment scheme shown recently to achieve the capacity of certain wireless networks within $o(\log(SNR))$. In this work, interference alignment scheme is also found to be optimal in achieving the degrees of freedom of the K user $M \times N$ MIMO Gaussian interference channel if the ratio $\frac{\max(M, N)}{\min(M, N)}$ is equal to an integer with time-varying channel coefficients drawn from a continuous distribution. We also explore the achievable degrees of freedom for the MIMO interference channel with constant channel coefficients using interference alignment combined with zero forcing. We provide some examples where using interference alignment can achieve more degrees of freedom than merely zero forcing.

APPENDIX I PROOF OF THEOREM 2

Proof: Let $\Gamma = KR(K - R - 1)$. We will develop a coding scheme based on interference alignment to achieve a total of $(R + 1)R(n + 1)^\Gamma + (K - R - 1)Rn^\Gamma$ degrees of freedom over a $\mu_n = (R + 1)(n + 1)^\Gamma$ symbol extension of the original channel. Hence, a total of $\frac{(R+1)R(n+1)^\Gamma + (K-R-1)Rn^\Gamma}{(R+1)(n+1)^\Gamma}$ degrees of freedom per orthogonal dimension can be achieved for any arbitrary $n \in \mathbb{N}$. Taking supremum over all n proves the total number of degrees of freedom is equal to $\frac{RK}{R+1}$ as desired. Specifically, over the extended channel, user $i = 1, 2, \dots, R + 1$ achieves $R(n + 1)^\Gamma$ degrees of freedom and other user $i = R + 2, R + 3, \dots, K$ achieves Rn^Γ degrees of freedom. As a result, user $i = 1, 2, \dots, R + 1$ achieves $\frac{R(n+1)^\Gamma}{(R+1)(n+1)^\Gamma}$ degrees of freedom and user $i = R + 2, R + 3, \dots, K$ achieves $\frac{Rn^\Gamma}{(R+1)(n+1)^\Gamma}$ degrees of freedom per channel use, i.e.

$$d_i = \frac{R(n + 1)^\Gamma}{(R + 1)(n + 1)^\Gamma} \quad i = 1, 2, \dots, R + 1 \quad d_i = \frac{Rn^\Gamma}{(R + 1)(n + 1)^\Gamma} \quad i = R + 2, R + 3, \dots, K \quad (25)$$

This implies that

$$d_1 + d_2 + \dots + d_K \geq \sup_n \frac{(R + 1)R(n + 1)^\Gamma + (K - R - 1)Rn^\Gamma}{(R + 1)(n + 1)^\Gamma} = \frac{KR}{R + 1} \quad (26)$$

In the extended channel, the signal vector at the k^{th} user's receiver can be expressed as

$$\bar{\mathbf{Y}}^{[k]}(t) = \sum_{j=1}^K \bar{\mathbf{H}}^{[kj]}(t) \bar{\mathbf{X}}^{[j]}(t) + \bar{\mathbf{Z}}^{[k]}(t)$$

where $\bar{\mathbf{X}}^{[j]}(t)$ is a $\mu_n \times 1$ column vector representing the μ_n symbol extension of the transmitted symbol $x^{[j]}(t)$, i.e.

$$\bar{\mathbf{X}}^{[j]}(t) \triangleq \begin{bmatrix} x^{[j]}(\mu_n(t - 1) + 1) \\ x^{[j]}(\mu_n(t - 1) + 2) \\ \vdots \\ x^{[j]}(\mu_n t) \end{bmatrix}$$

Similarly, $\bar{\mathbf{Y}}(t)$ and $\bar{\mathbf{Z}}(t)$ represent μ_n symbol extensions of the $\mathbf{Y}(t)$ and $\mathbf{Z}(t)$ respectively. $\bar{\mathbf{H}}^{[kj]}(t)$ is a $R\mu_n \times \mu_n$ matrix representing the μ_n symbol extension of the channel, i.e.

$$\bar{\mathbf{H}}^{[kj]}(t) = \begin{bmatrix} \mathbf{h}^{[kj]}(\mu_n(t-1)+1) & \mathbf{0} & \dots & \mathbf{0} \\ \mathbf{0} & \mathbf{h}^{[kj]}(\mu_n(t-1)+2) & \dots & \mathbf{0} \\ \vdots & \vdots & \ddots & \vdots \\ \mathbf{0} & \mathbf{0} & \dots & \mathbf{h}^{[kj]}(\mu_n t) \end{bmatrix} \quad (27)$$

where $\mathbf{h}^{[kj]}$ is the $R \times 1$ channel vector. Message W_j ($j = 1, 2, \dots, R+1$) is encoded at Transmitter j into $R(n+1)^\Gamma$ independent streams $x_m^{[j]}(t)$, $m = 1, 2, \dots, R(n+1)^\Gamma$ along the same set of vectors $\bar{\mathbf{v}}_m^{[1]}(t)$ so that $\bar{\mathbf{X}}^{[j]}(t)$ is

$$\bar{\mathbf{X}}^{[j]}(t) = \sum_{m=1}^{R(n+1)^\Gamma} x_m^{[j]}(t) \bar{\mathbf{v}}_m^{[1]}(t) = \bar{\mathbf{V}}^{[1]}(t) \mathbf{X}^{[j]}(t)$$

where $\mathbf{X}^{[j]}(t)$ is a $R(n+1)^\Gamma \times 1$ column vector and $\bar{\mathbf{V}}^{[1]}(t)$ is a $(R+1)(n+1)^\Gamma \times R(n+1)^\Gamma$ dimensional matrix. Similarly, W_j ($j = R+2, \dots, K$) is encoded at Transmitter j into Rn^Γ independent streams $x_m^{[j]}(t)$, $m = 1, 2, \dots, Rn^\Gamma$ along the same set of vectors $\bar{\mathbf{v}}_m^{[2]}(t)$ so that

$$\bar{\mathbf{X}}^{[j]}(t) = \sum_{m=1}^{Rn^\Gamma} x_m^{[j]}(t) \bar{\mathbf{v}}_m^{[2]}(t) = \bar{\mathbf{V}}^{[2]}(t) \mathbf{X}^{[j]}(t)$$

The received signal at the k^{th} receiver can then be written as

$$\bar{\mathbf{Y}}^{[k]}(t) = \sum_{j=1}^{R+1} \bar{\mathbf{H}}^{[kj]}(t) \bar{\mathbf{V}}^{[1]}(t) \mathbf{X}^{[j]}(t) + \sum_{j=R+2}^K \bar{\mathbf{H}}^{[kj]}(t) \bar{\mathbf{V}}^{[2]}(t) \mathbf{X}^{[j]}(t) + \bar{\mathbf{Z}}^{[k]}(t)$$

We wish to design the direction vectors $\bar{\mathbf{V}}^{[1]}$ and $\bar{\mathbf{V}}^{[2]}$ so that signal spaces are aligned at receivers where they constitute interference while they are separable at receivers where they are desired. As a result, each receiver can decode its desired signal by zero forcing the interference signals.

First consider Receiver k , $\forall k = 1, 2, \dots, R+1$. Every receiver needs a $R(n+1)^\Gamma$ interference free dimension out of the $R(R+1)(n+1)^\Gamma$ dimensional signal space. Thus, the dimension of the signal space spanned by the interference signal vectors cannot be more than $R^2(n+1)^\Gamma$. Notice that all the interference vectors from Transmitter $1, 2, \dots, k-1, k+1, \dots, R+1$ span a $R^2(n+1)^\Gamma$ dimensional subspace in the $R(R+1)(n+1)^\Gamma$ dimensional signal space. Hence, we can align the interference signal vectors from Transmitter j , $\forall j = R+2, R+3, \dots, K$ within this $R^2(n+1)^\Gamma$ dimensional subspace. Mathematically, we have

$$\text{span}(\bar{\mathbf{H}}^{[kj]} \bar{\mathbf{V}}^{[2]}) \subset \text{span}(\left[\bar{\mathbf{H}}^{[k1]} \bar{\mathbf{V}}^{[1]} \quad \bar{\mathbf{H}}^{[k2]} \bar{\mathbf{V}}^{[1]} \quad \dots \quad \bar{\mathbf{H}}^{[k(k-1)]} \bar{\mathbf{V}}^{[1]} \quad \bar{\mathbf{H}}^{[k(k+1)]} \bar{\mathbf{V}}^{[1]} \quad \dots \quad \bar{\mathbf{H}}^{[k(R+1)]} \bar{\mathbf{V}}^{[1]} \right])$$

where $\text{span}(\mathbf{A})$ represents the space spanned by the columns of matrix \mathbf{A} . The above equation can be expressed equivalently as

$$\text{span}(\bar{\mathbf{H}}^{[kj]} \bar{\mathbf{V}}^{[2]}) \subset \text{span}(\left[\bar{\mathbf{H}}^{[k1]} \quad \bar{\mathbf{H}}^{[k2]} \quad \dots \quad \bar{\mathbf{H}}^{[k(k-1)]} \quad \bar{\mathbf{H}}^{[k(k+1)]} \quad \dots \quad \bar{\mathbf{H}}^{[k(R+1)]} \right] \begin{bmatrix} \bar{\mathbf{V}}^{[1]} & \mathbf{0} & \dots & \mathbf{0} & \mathbf{0} & \dots & \mathbf{0} \\ \mathbf{0} & \bar{\mathbf{V}}^{[1]} & \dots & \mathbf{0} & \mathbf{0} & \dots & \mathbf{0} \\ \vdots & \vdots & \ddots & \vdots & \vdots & \ddots & \vdots \\ \mathbf{0} & \mathbf{0} & \dots & \bar{\mathbf{V}}^{[1]} & \dots & \dots & \mathbf{0} \\ \mathbf{0} & \mathbf{0} & \dots & \dots & \bar{\mathbf{V}}^{[1]} & \dots & \mathbf{0} \\ \vdots & \vdots & \ddots & \vdots & \vdots & \ddots & \vdots \\ \mathbf{0} & \mathbf{0} & \dots & \mathbf{0} & \mathbf{0} & \dots & \bar{\mathbf{V}}^{[1]} \end{bmatrix} \right)$$

Notice that $[\bar{\mathbf{H}}^{[k1]} \bar{\mathbf{H}}^{[k2]} \dots \bar{\mathbf{H}}^{[k(k-1)]} \bar{\mathbf{H}}^{[k(k+1)]} \dots \bar{\mathbf{H}}^{[k(R+1)]}]$ is a $R\mu_n \times R\mu_n$ square matrix with full rank almost surely. Thus, the above equation can be expressed equivalently as

$$\text{span}\left(\underbrace{[\bar{\mathbf{H}}^{[k1]} \bar{\mathbf{H}}^{[k2]} \dots \bar{\mathbf{H}}^{[k(k-1)]} \bar{\mathbf{H}}^{[k(k+1)]} \dots \bar{\mathbf{H}}^{[k(R+1)]}]^{-1} \bar{\mathbf{H}}^{[kj]} \bar{\mathbf{V}}^{[2]}}_{\mathbf{T}^{[kj]}}\right) \subset \text{span}\left(\begin{bmatrix} \bar{\mathbf{V}}^{[1]} & \mathbf{0} & \dots & \mathbf{0} & \mathbf{0} & \dots & \mathbf{0} \\ \mathbf{0} & \bar{\mathbf{V}}^{[1]} & \dots & \mathbf{0} & \mathbf{0} & \dots & \mathbf{0} \\ \vdots & \vdots & \ddots & \vdots & \vdots & \ddots & \vdots \\ \mathbf{0} & \mathbf{0} & \dots & \bar{\mathbf{V}}^{[1]} & \dots & \dots & \mathbf{0} \\ \mathbf{0} & \mathbf{0} & \dots & \dots & \bar{\mathbf{V}}^{[1]} & \dots & \mathbf{0} \\ \vdots & \vdots & \ddots & \vdots & \vdots & \ddots & \vdots \\ \mathbf{0} & \mathbf{0} & \dots & \mathbf{0} & \mathbf{0} & \dots & \bar{\mathbf{V}}^{[1]} \end{bmatrix}\right) \quad (28)$$

Note that $\mathbf{T}^{[kj]}$ is a $R\mu_n \times \mu_n$ matrix and can be written in a block matrix form:

$$\mathbf{T}^{[kj]} = \begin{bmatrix} \mathbf{T}_1^{[kj]} \\ \mathbf{T}_2^{[kj]} \\ \vdots \\ \mathbf{T}_R^{[kj]} \end{bmatrix} \quad (29)$$

where each block $\mathbf{T}_i^{[kj]}$ is a $\mu_n \times \mu_n$ matrix. Then, (28) can be expressed equivalently as

$$\text{span}\left(\begin{bmatrix} \mathbf{T}_1^{[kj]} \bar{\mathbf{V}}^{[2]} \\ \mathbf{T}_2^{[kj]} \bar{\mathbf{V}}^{[2]} \\ \vdots \\ \mathbf{T}_R^{[kj]} \bar{\mathbf{V}}^{[2]} \end{bmatrix}\right) \subset \text{span}\left(\begin{bmatrix} \bar{\mathbf{V}}^{[1]} & \mathbf{0} & \dots & \mathbf{0} \\ \mathbf{0} & \bar{\mathbf{V}}^{[1]} & \dots & \mathbf{0} \\ \vdots & \vdots & \ddots & \vdots \\ \mathbf{0} & \mathbf{0} & \dots & \bar{\mathbf{V}}^{[1]} \end{bmatrix}\right)$$

The above condition can be satisfied if

$$\mathbf{T}_i^{[kj]} \bar{\mathbf{V}}^{[2]} \prec \bar{\mathbf{V}}^{[1]} \quad \forall k = 1, \dots, R+1 \quad j = R+2, \dots, K \quad i = 1, \dots, R \quad (30)$$

where $\mathbf{P} \prec \mathbf{Q}$ means that the set of column vectors of matrix \mathbf{P} is a subset of the set of column vectors of matrix \mathbf{Q} .

Then consider Receiver k , $\forall k = R+2, R+3, \dots, K$. To get a Rn^Γ interference free dimension signal space, the dimension of the signal space spanned by the interference vectors cannot be more than $R(R+1)(n+1)^\Gamma - Rn^\Gamma$ at each receiver. This can be achieved if all interference vectors from Transmitter j , $\forall j = R+2, \dots, k-1, k+1, \dots, K$ and Rn^Γ interference vectors from Transmitter $R+1$ are aligned within the signal space spanned by interference vectors from transmitter $1, 2, \dots, R$. We first consider aligning the interference from Transmitter $R+2, \dots, k-1, k+1, \dots, K$. Mathematically, we choose the following alignments:

$$\begin{aligned} \text{span}(\bar{\mathbf{H}}^{[kj]} \bar{\mathbf{V}}^{[2]}) &\subset \text{span}([\bar{\mathbf{H}}^{[k1]} \bar{\mathbf{V}}^{[1]} \bar{\mathbf{H}}^{[k2]} \bar{\mathbf{V}}^{[1]} \dots \bar{\mathbf{H}}^{[kR]} \bar{\mathbf{V}}^{[1]}) \\ \Rightarrow \text{span}(\bar{\mathbf{H}}^{[kj]} \bar{\mathbf{V}}^{[2]}) &\subset \text{span}\left([\bar{\mathbf{H}}^{[k1]} \bar{\mathbf{H}}^{[k2]} \dots \bar{\mathbf{H}}^{[kR]}] \begin{bmatrix} \bar{\mathbf{V}}^{[1]} & \mathbf{0} & \dots & \mathbf{0} \\ \mathbf{0} & \bar{\mathbf{V}}^{[1]} & \dots & \mathbf{0} \\ \vdots & \vdots & \ddots & \vdots \\ \mathbf{0} & \mathbf{0} & \dots & \bar{\mathbf{V}}^{[1]} \end{bmatrix}\right) \end{aligned}$$

Notice that $[\bar{\mathbf{H}}^{[k1]} \bar{\mathbf{H}}^{[k2]} \dots \bar{\mathbf{H}}^{[kR]}]$ is a $R\mu_n \times R\mu_n$ square matrix with full rank almost surely. Thus, the above equation can be expressed equivalently as

$$\text{span}\left(\underbrace{[\bar{\mathbf{H}}^{[k1]} \bar{\mathbf{H}}^{[k2]} \dots \bar{\mathbf{H}}^{[kR]}]^{-1} \bar{\mathbf{H}}^{[kj]} \bar{\mathbf{V}}^{[2]}}_{\mathbf{T}^{[kj]}}\right) \subset \text{span}\left(\begin{bmatrix} \bar{\mathbf{V}}^{[1]} & \mathbf{0} & \dots & \mathbf{0} \\ \mathbf{0} & \bar{\mathbf{V}}^{[1]} & \dots & \mathbf{0} \\ \vdots & \vdots & \ddots & \vdots \\ \mathbf{0} & \mathbf{0} & \dots & \bar{\mathbf{V}}^{[1]} \end{bmatrix}\right) \quad (31)$$

Note that $\mathbf{T}^{[kj]}$ is a $R\mu_n \times \mu_n$ matrix and can be written in a block matrix form:

$$\mathbf{T}^{[kj]} = \begin{bmatrix} \mathbf{T}_1^{[kj]} \\ \mathbf{T}_2^{[kj]} \\ \vdots \\ \mathbf{T}_R^{[kj]} \end{bmatrix}$$

where each block $\mathbf{T}_i^{[kj]}$ is a $\mu_n \times \mu_n$ matrix. Then, (31) can be expressed as

$$\text{span}\left(\begin{bmatrix} \mathbf{T}_1^{[kj]} \bar{\mathbf{V}}^{[2]} \\ \mathbf{T}_2^{[kj]} \bar{\mathbf{V}}^{[2]} \\ \vdots \\ \mathbf{T}_R^{[kj]} \bar{\mathbf{V}}^{[2]} \end{bmatrix}\right) \subset \text{span}\left(\begin{bmatrix} \bar{\mathbf{V}}^{[1]} & \mathbf{0} & \dots & \mathbf{0} \\ \mathbf{0} & \bar{\mathbf{V}}^{[1]} & \dots & \mathbf{0} \\ \vdots & \vdots & \ddots & \vdots \\ \mathbf{0} & \mathbf{0} & \dots & \bar{\mathbf{V}}^{[1]} \end{bmatrix}\right)$$

The above condition can be satisfied if

$$\mathbf{T}_i^{[kj]} \bar{\mathbf{V}}^{[2]} \prec \bar{\mathbf{V}}^{[1]} \quad k = R+2, R+3, \dots, K \quad j = R+2, \dots, k-1, k+1, \dots, K \quad i = 1, \dots, R \quad (32)$$

Now consider aligning Rn^Γ interference vectors from Transmitter $R+1$ at Receiver k , $\forall k = R+2, R+3, \dots, K$. This can be achieved if the space spanned by Rn^Γ columns of $\bar{\mathbf{H}}^{[k(R+1)]} \bar{\mathbf{V}}^{[1]}$ is aligned within the range of $[\bar{\mathbf{H}}^{[k1]} \bar{\mathbf{V}}^{[1]} \dots \bar{\mathbf{H}}^{[kR]} \bar{\mathbf{V}}^{[1]}]$. Since $\bar{\mathbf{V}}^{[1]}$ is a $\mu_n \times R(n+1)^\Gamma$ matrix, we can write it as $\bar{\mathbf{V}}^{[1]} = [\bar{\mathbf{V}}_u^{[1]} \bar{\mathbf{V}}_{\epsilon_n}^{[1]}]$ where $\bar{\mathbf{V}}_u^{[1]}$ and $\bar{\mathbf{V}}_{\epsilon_n}^{[1]}$ are $\mu_n \times Rn^\Gamma$ and $\mu_n \times (R(n+1)^\Gamma - Rn^\Gamma)$ matrices, respectively. We assume the space spanned by the columns of $\bar{\mathbf{H}}^{[k(R+1)]} \bar{\mathbf{V}}_u^{[1]}$ is aligned within the space spanned by the interference from Transmitter 1, 2, ..., R . From equation (30), we have

$$\mathbf{T}_1^{[1(R+2)]} \bar{\mathbf{V}}^{[2]} \prec \bar{\mathbf{V}}^{[1]}$$

This implies that Rn^Γ columns of $\bar{\mathbf{V}}^{[1]}$ are equal to the columns of $\mathbf{T}_1^{[1(R+2)]} \bar{\mathbf{V}}^{[2]}$. Without loss of generality, we assume that $\bar{\mathbf{V}}_u^{[1]} = \mathbf{T}_1^{[1(R+2)]} \bar{\mathbf{V}}^{[2]}$. Thus, to satisfy the interference alignment requirement, we choose the following alignments:

$$\begin{aligned} \text{span}(\bar{\mathbf{H}}^{[k(R+1)]} \bar{\mathbf{V}}_u^{[1]}) &= \text{span}(\bar{\mathbf{H}}^{[k(R+1)]} \mathbf{T}_1^{[1(R+2)]} \bar{\mathbf{V}}^{[2]}) \subset \text{span}([\bar{\mathbf{H}}^{[k1]} \bar{\mathbf{V}}^{[1]} \bar{\mathbf{H}}^{[k2]} \bar{\mathbf{V}}^{[1]} \dots \bar{\mathbf{H}}^{[kR]} \bar{\mathbf{V}}^{[1]}]) \\ &\Rightarrow \text{span}(\bar{\mathbf{H}}^{[k(R+1)]} \mathbf{T}_1^{[1(R+2)]} \bar{\mathbf{V}}^{[2]}) \subset \text{span}\left(\begin{bmatrix} \bar{\mathbf{H}}^{[k1]} & \bar{\mathbf{H}}^{[k2]} & \dots & \bar{\mathbf{H}}^{[kR]} \end{bmatrix} \begin{bmatrix} \bar{\mathbf{V}}^{[1]} & \mathbf{0} & \dots & \mathbf{0} \\ \mathbf{0} & \bar{\mathbf{V}}^{[1]} & \dots & \mathbf{0} \\ \vdots & \vdots & \ddots & \vdots \\ \mathbf{0} & \mathbf{0} & \dots & \bar{\mathbf{V}}^{[1]} \end{bmatrix}\right) \\ &\Rightarrow \text{span}\left(\underbrace{[\bar{\mathbf{H}}^{[k1]} \bar{\mathbf{H}}^{[k2]} \dots \bar{\mathbf{H}}^{[kR]}]^{-1} \bar{\mathbf{H}}^{[k(R+1)]} \mathbf{T}_1^{[1(R+2)]}}_{\mathbf{T}^{[k(R+1)]}} \bar{\mathbf{V}}^{[2]}\right) \subset \text{span}\left(\begin{bmatrix} \bar{\mathbf{V}}^{[1]} & \mathbf{0} & \dots & \mathbf{0} \\ \mathbf{0} & \bar{\mathbf{V}}^{[1]} & \dots & \mathbf{0} \\ \vdots & \vdots & \ddots & \vdots \\ \mathbf{0} & \mathbf{0} & \dots & \bar{\mathbf{V}}^{[1]} \end{bmatrix}\right) \end{aligned}$$

Note that $\mathbf{T}^{[k(R+1)]}$ is a $R\mu_n \times \mu_n$ matrix and can be written in a block matrix form:

$$\mathbf{T}^{[k(R+1)]} = \begin{bmatrix} \mathbf{T}_1^{[k(R+1)]} \\ \mathbf{T}_2^{[k(R+1)]} \\ \vdots \\ \mathbf{T}_R^{[k(R+1)]} \end{bmatrix}$$

where each block $\mathbf{T}_i^{[k(R+1)]}$ is a $\mu_n \times \mu_n$ matrix. Then, the above equation can be expressed as

$$\text{span}\left(\begin{bmatrix} \mathbf{T}_1^{[k(R+1)]}\bar{\mathbf{V}}^{[2]} \\ \mathbf{T}_2^{[k(R+1)]}\bar{\mathbf{V}}^{[2]} \\ \vdots \\ \mathbf{T}_R^{[k(R+1)]}\bar{\mathbf{V}}^{[2]} \end{bmatrix}\right) \subset \text{span}\left(\begin{bmatrix} \bar{\mathbf{V}}^{[1]} & \mathbf{0} & \dots & \mathbf{0} \\ \mathbf{0} & \bar{\mathbf{V}}^{[1]} & \dots & \mathbf{0} \\ \vdots & \vdots & \ddots & \vdots \\ \mathbf{0} & \mathbf{0} & \dots & \bar{\mathbf{V}}^{[1]} \end{bmatrix}\right)$$

The above condition can be satisfied if

$$\mathbf{T}_i^{[k(R+1)]}\bar{\mathbf{V}}^{[2]} \prec \bar{\mathbf{V}}^{[1]} \quad k = R+2, R+3, \dots, K \quad i = 1, \dots, R \quad (33)$$

Thus, interference alignment is ensured by choosing $\bar{\mathbf{V}}^{[1]}$ and $\bar{\mathbf{V}}^{[2]}$ to satisfy (30), (32), (33). Note that these conditions can be expressed as

$$\mathbf{T}_i^{[kj]}\bar{\mathbf{V}}^{[2]} \prec \bar{\mathbf{V}}^{[1]} \quad \forall (k, j) \in A \quad i = 1, 2, \dots, R \quad (34)$$

where $A = \{(k, j) : (k, j) \in \{1, 2, \dots, R+1\} \times \{R+2, \dots, K\}\} \cup \{(k, j) : (k, j) \in \{R+2, \dots, K\} \times \{R+1, \dots, K\}, k \neq j\}$. Therefore, there are $KR(K-R-1)$ such equations. We need to choose $R(n+1)^\Gamma$ column vectors for $\bar{\mathbf{V}}^{[1]}$ and Rn^Γ column vectors for $\bar{\mathbf{V}}^{[2]}$. Let \mathbf{w} be a $\mu_n \times 1$ column vector $\mathbf{w} = [1 \ 1 \ \dots \ 1]^T$. The sets of column vectors of $\bar{\mathbf{V}}^{[1]}$ and $\bar{\mathbf{V}}^{[2]}$ are chosen to be equal to the sets $\bar{V}^{[1]}$ and $\bar{V}^{[2]}$ respectively where

$$\bar{V}^{[1]} = \bigcup_{m=0}^{R-1} \left\{ \left(\prod_{i=1, \dots, R, (k,j) \in A} (\mathbf{T}_i^{[kj]})^{\alpha_i^{[kj]}} \right) \mathbf{w} : \alpha_i^{[kj]} \in \{mn+m+1, mn+m+2, \dots, (m+1)n+m+1\} \right\} \quad (35)$$

$$\bar{V}^{[2]} = \bigcup_{m=0}^{R-1} \left\{ \left(\prod_{i=1, \dots, R, (k,j) \in A} (\mathbf{T}_i^{[kj]})^{\alpha_i^{[kj]}} \right) \mathbf{w} : \alpha_i^{[kj]} \in \{mn+m+1, mn+m+2, \dots, (m+1)n+m\} \right\} \quad (36)$$

Note that the above construction requires the commutative property of multiplication of matrices $\mathbf{T}_i^{[kj]}$. Therefore, it requires $\mathbf{T}_i^{[kj]}$ to be diagonal matrices. Next, we will show this is true. We illustrate this for the case when $k = R+2, \dots, K$ and $j = R+2, \dots, k-1, k+1, \dots, K$. Similar arguments can be applied to other cases. Notice that $[\bar{\mathbf{H}}^{[k1]} \ \bar{\mathbf{H}}^{[k2]} \ \dots \ \bar{\mathbf{H}}^{[kR]}]$ is a $R\mu_n \times R\mu_n$ square matrix:

$$\begin{bmatrix} \bar{\mathbf{H}}^{[k1]} & \bar{\mathbf{H}}^{[k2]} & \dots & \bar{\mathbf{H}}^{[kR]} \end{bmatrix} = \begin{bmatrix} \mathbf{h}^{[k1]}_{(\mu_n(t-1)+1)} & \mathbf{0}_{R \times 1} & \dots & \mathbf{0}_{R \times 1} & \dots & \mathbf{h}^{[kR]}_{(\mu_n(t-1)+1)} & \mathbf{0}_{R \times 1} & \dots & \mathbf{0}_{R \times 1} \\ \mathbf{0}_{R \times 1} & \mathbf{h}^{[k1]}_{(\mu_n(t-1)+2)} & \dots & \mathbf{0}_{R \times 1} & \dots & \mathbf{0}_{R \times 1} & \mathbf{h}^{[kR]}_{(\mu_n(t-1)+2)} & \dots & \mathbf{0}_{R \times 1} \\ \vdots & \vdots & \ddots & \vdots & \dots & \vdots & \vdots & \ddots & \vdots \\ \mathbf{0}_{R \times 1} & \mathbf{0}_{R \times 1} & \dots & \mathbf{h}^{[k1]}_{(\mu_n t)} & \dots & \mathbf{0}_{R \times 1} & \mathbf{0}_{R \times 1} & \dots & \mathbf{h}^{[kR]}_{(\mu_n t)} \end{bmatrix}$$

Then,

$$[\bar{\mathbf{H}}^{[k1]} \ \bar{\mathbf{H}}^{[k2]} \ \dots \ \bar{\mathbf{H}}^{[kR]}]^{-1} = \begin{bmatrix} \mathbf{u}^{[k1]}(\mu_n(t-1)+1)_{1 \times R} & \mathbf{0}_{1 \times R} & \dots & \mathbf{0}_{1 \times R} \\ \mathbf{0}_{1 \times R} & \mathbf{u}^{[k1]}(\mu_n(t-1)+2)_{1 \times R} & \dots & \mathbf{0}_{1 \times R} \\ \vdots & \vdots & \ddots & \vdots \\ \mathbf{0}_{1 \times R} & \mathbf{0}_{1 \times R} & \dots & \mathbf{u}^{[k1]}(\mu_n(t-1)+\mu_n)_{1 \times R} \\ \mathbf{u}^{[k2]}(\mu_n(t-1)+1)_{1 \times R} & \mathbf{0}_{1 \times R} & \dots & \mathbf{0}_{1 \times R} \\ \mathbf{0}_{1 \times R} & \mathbf{u}^{[k2]}(\mu_n(t-1)+2)_{1 \times R} & \dots & \mathbf{0}_{1 \times R} \\ \vdots & \vdots & \ddots & \vdots \\ \mathbf{0}_{1 \times R} & \mathbf{0}_{1 \times R} & \dots & \mathbf{u}^{[k2]}(\mu_n(t-1)+\mu_n)_{1 \times R} \\ \vdots & \vdots & \ddots & \vdots \\ \mathbf{u}^{[kR]}(\mu_n(t-1)+1)_{1 \times R} & \mathbf{0}_{1 \times R} & \dots & \mathbf{0}_{1 \times R} \\ \mathbf{0}_{1 \times R} & \mathbf{u}^{[kR]}(\mu_n(t-1)+2)_{1 \times R} & \dots & \mathbf{0}_{1 \times R} \\ \vdots & \vdots & \ddots & \vdots \\ \mathbf{0}_{1 \times R} & \mathbf{0}_{1 \times R} & \dots & \mathbf{u}^{[kR]}(\mu_n(t-1)+\mu_n)_{1 \times R} \end{bmatrix}$$

where $\mathbf{u}^{[kj]}(\mu_n(t-1)+\kappa), \forall \kappa = 1, 2, \dots, \mu_n$ is a $1 \times R$ row vector and

$$\begin{bmatrix} \mathbf{h}^{[k1]}(\mu_n(t-1)+\kappa) & \mathbf{h}^{[k2]}(\mu_n(t-1)+\kappa) & \dots & \mathbf{h}^{[kR]}(\mu_n(t-1)+\kappa) \end{bmatrix}^{-1} = \begin{bmatrix} \mathbf{u}^{[k1]}(\mu_n(t-1)+\kappa) \\ \mathbf{u}^{[k2]}(\mu_n(t-1)+\kappa) \\ \vdots \\ \mathbf{u}^{[kR]}(\mu_n(t-1)+\kappa) \end{bmatrix} \quad \kappa = 1, 2, \dots, \mu_n.$$

Recall

$$\mathbf{T}^{[kj]} = \begin{bmatrix} \mathbf{T}_1^{[kj]} \\ \mathbf{T}_2^{[kj]} \\ \vdots \\ \mathbf{T}_R^{[kj]} \end{bmatrix} = [\bar{\mathbf{H}}^{[k1]} \ \bar{\mathbf{H}}^{[k2]} \ \dots \ \bar{\mathbf{H}}^{[kR]}]^{-1} \bar{\mathbf{H}}^{[kj]} \ \bar{\mathbf{H}}^{[kj]}(t) = \begin{bmatrix} \mathbf{h}^{[kj]}(\mu_n(t-1)+1) & \mathbf{0} & \dots & \mathbf{0} \\ \mathbf{0} & \mathbf{h}^{[kj]}(\mu_n(t-1)+2) & \dots & \mathbf{0} \\ \vdots & \vdots & \ddots & \vdots \\ \mathbf{0} & \mathbf{0} & \dots & \mathbf{h}^{[kj]}(\mu_n t) \end{bmatrix}$$

Thus, $\forall i = 1, 2, \dots, R$

$$\mathbf{T}_i^{[kj]} = \begin{bmatrix} \mathbf{u}^{[ki]}(\mu_n(t-1)+1)\mathbf{h}^{[kj]}(\mu_n(t-1)+1) & 0 & \dots & 0 \\ 0 & \mathbf{u}^{[ki]}(\mu_n(t-1)+2)\mathbf{h}^{[kj]}(\mu_n(t-1)+2) & \dots & 0 \\ \vdots & \vdots & \ddots & \vdots \\ 0 & 0 & \dots & \mathbf{u}^{[ki]}(\mu_n t)\mathbf{h}^{[kj]}(\mu_n t) \end{bmatrix} \quad (37)$$

Hence, $\mathbf{T}_i^{[kj]}$ are diagonal matrices with diagonal entries $\mathbf{u}^{[ki]}(\mu_n(t-1)+\kappa)\mathbf{h}^{[kj]}(\mu_n(t-1)+\kappa), \forall \kappa = 1, \dots, \mu_n$.

Through interference alignment, we ensure that the dimension of the interference is small enough. Now we need to verify that the desired signal vectors are linearly independent of the interference vectors so that each receiver can separate the signal and interference signals. Consider Receiver 1. Since all interference vectors are aligned in the signal space spanned by interference from transmitter 2, 3 \dots , $R+1$, it suffices to verify that columns of $\bar{\mathbf{H}}^{[11]}\bar{\mathbf{V}}^{[1]}$ are linearly independent of columns of $[\bar{\mathbf{H}}^{[12]}\bar{\mathbf{V}}^{[1]} \ \dots \ \bar{\mathbf{H}}^{[1(R+1)]}\bar{\mathbf{V}}^{[1]}]$ almost surely. Notice that the direct channel matrix $\bar{\mathbf{H}}^{[11]}$ does not appear in the interference alignment equations and $\bar{\mathbf{V}}^{[1]}$ is chosen independently of $\bar{\mathbf{H}}^{[11]}$. Then, the desired signal $\bar{\mathbf{V}}^{[1]}$ undergoes an independent linear transformation by multiplying $\bar{\mathbf{H}}^{[11]}$. Thus, columns of $\bar{\mathbf{H}}^{[11]}\bar{\mathbf{V}}^{[1]}$ are linearly independent of columns of $[\bar{\mathbf{H}}^{[12]}\bar{\mathbf{V}}^{[1]} \ \dots \ \bar{\mathbf{H}}^{[1(R+1)]}\bar{\mathbf{V}}^{[1]}]$ almost surely as long as all entries of $\bar{\mathbf{V}}^{[1]}$ are not equal to zero with probability one. If there are some entries of $\bar{\mathbf{V}}^{[1]}$ are equal to zero, then due to the block diagonal structure of $\bar{\mathbf{H}}^{[11]}$ the desired signal vectors are linearly dependent of the interference vectors. For example, consider three 3×3 diagonal matrix $\mathbf{H}^{[1]}, \mathbf{H}^{[2]}, \mathbf{H}^{[3]}$ whose entries are drawn according to a continuous distribution. \mathbf{v} is a 3×1 vector whose entries depend on entries of $\mathbf{H}^{[2]}, \mathbf{H}^{[3]}$ and are non-zero with probability one. Vectors $\mathbf{H}^{[2]}\mathbf{v}$ and $\mathbf{H}^{[3]}\mathbf{v}$ span a plane in the three dimensional space. Now vector \mathbf{v} undergoes a random linear transformation by multiplying $\mathbf{H}^{[1]}$. The probability that vector $\mathbf{H}^{[1]}\mathbf{v}$ lies in that plane is zero. If \mathbf{v} has one zero entry, for example $\mathbf{v} = [1 \ 1 \ 0]^T$, then $\mathbf{H}^{[1]}\mathbf{v}, \mathbf{H}^{[2]}\mathbf{v}$ and $\mathbf{H}^{[3]}\mathbf{v}$ are two dimensional vectors in the three dimensional

vector space. Hence they are linearly dependent. Next we will verify all entries of $\bar{\mathbf{V}}^{[1]}$ and $\bar{\mathbf{V}}^{[2]}$ are nonzero with probability one through their construction from (35) and (36). From (35), (36) and (37), it can be seen that each entry of $\bar{\mathbf{V}}^{[1]}$ and $\bar{\mathbf{V}}^{[2]}$ is a product of the power of some $\mathbf{u}^{[ki]}(\mu_n(t-1) + \kappa)\mathbf{h}^{[kj]}(\mu_n(t-1) + \kappa)$. To verify each entry of $\bar{\mathbf{V}}^{[1]}$ and $\bar{\mathbf{V}}^{[2]}$ is not equal to zero with probability one, we only need to verify $\mathbf{u}^{[ki]}(\mu_n(t-1) + \kappa)\mathbf{h}^{[kj]}(\mu_n(t-1) + \kappa)$ is not equal to zero with probability one. Since each entry of $\mathbf{h}^{[kj]}(\mu_n(t-1) + \kappa)$ is drawn from a continuous distribution, $\mathbf{u}^{[ki]}(\mu_n(t-1) + \kappa)\mathbf{h}^{[kj]}(\mu_n(t-1) + \kappa) = 0$ if and only if all entries of $\mathbf{u}^{[ki]}(\mu_n(t-1) + \kappa)$ are equal to zero. However, $\mathbf{u}^{[ki]}(\mu_n(t-1) + \kappa)$ is a row of the inverse of the $R \times R$ square matrix. Thus, not all entries of $\mathbf{u}^{[ki]}(\mu_n(t-1) + \kappa)$ are equal to zero with probability one. As a result, all entries of $\bar{\mathbf{V}}^{[1]}$ and $\bar{\mathbf{V}}^{[2]}$ are not equal to zero with probability one. To this end, we conclude that at Receiver 1 the desired signal vectors are linearly independent with the interference signal vectors.

Similar arguments can be applied at Receiver 2, 3, \dots , K to show that the desired signal vectors are linearly independent of the interference vectors. Thus, each receiver can decode its desired streams using zero forcing. As a result, each user can achieve $\frac{R}{R+1}$ degrees of freedom per channel use for a total of $\frac{R}{R+1}K$ degrees of freedom with probability one. ■

APPENDIX II

THE ACHIEVABLE DEGREES OF FREEDOM OF THE MIMO GAUSSIAN INTERFERENCE CHANNEL WITH CONSTANT CHANNEL COEFFICIENTS

In this appendix, we consider the achievable degrees of freedom for some MIMO Gaussian interference channels with constant channel coefficients. Specifically, we consider the $R + 2$ user MIMO Gaussian interference channel where each transmitter has $M > 1$ antennas and receiver has RM , $R = 2, 3, \dots$ antennas. The main results of this section are presented in the following theorems:

Theorem 4: For the $R+2$ user MIMO Gaussian interference channel where each transmitter has $M > 1$ antennas and each receiver has RM , $R = 2, 3, \dots$, antennas with constant channel coefficients, $RM + \lfloor \frac{RM}{R^2+2R-1} \rfloor$ degrees of freedom can be achieved without channel extension.

Proof: The achievable scheme is provided in the following part. ■

Theorem 4 is interesting because it shows that when $\lfloor \frac{RM}{R^2+2R-1} \rfloor > 0$ and hence $M > R + 2 - \frac{1}{R}$, using interference alignment scheme combined with zero forcing can achieve more degrees of freedom than merely zero forcing. It also shows that the $R + 2$ user MIMO interference channel with M antennas at each transmitter and RM antennas at each receiver can achieve more degrees of freedom than $R + 1$ user with the same antenna deployment when $M > R + 2 - \frac{1}{R}$. For example, if $R = 2$, Theorem 4 shows that for the 4 user interference channel with M and $2M$ antennas at each transmitter and receiver respectively, $2M + \lfloor \frac{2M}{7} \rfloor$ degrees of freedom can be achieved using interference alignment. However, only $2M$ degrees of freedom can be achieved using zero forcing. Thus, when $M > 3$, using interference alignment combined with zero forcing can achieve more degrees of freedom than merely zero forcing. Similarly, only $2M$ degrees of freedom can be achieved on the 3 user interference channel with the same antenna deployment. Hence, when $M > 3$ more degrees of freedom can be achieved on the 4 user interference channel. While Theorem 4 indicates that when $M < R + 2$ using interference alignment combined with zero forcing may not achieve more degrees of freedom than zero forcing without channel extension, using interference alignment can achieve more degrees of freedom if we allow channel extension. We present the result in the following theorem:

Theorem 5: For the $R + 2$ user MIMO interference channel where each transmitter has M ($1 < M < R + 2$) antennas and each receiver has RM , $R = 2, 3, \dots$, antennas with constant channel coefficients, $RM + \frac{1}{\lceil \frac{R+2}{M} \rceil}$ degrees of freedom per orthogonal dimension can be achieved with $\lceil \frac{R+2}{M} \rceil$ channel extension.

Proof: The achievable scheme is provided in the following part. ■

Theorem 5 shows that if we allow channel extension, $\frac{1}{\lceil \frac{R+2}{M} \rceil}$ more degrees of freedom can be achieved using interference alignment combined with zero forcing than merely zero forcing. For example, when $R = 2, M = 2, \frac{1}{2}$ more degrees of freedom can be achieved using interference alignment.

A. Proof of Theorem 4

When $\lfloor \frac{RM}{R^2+2R-1} \rfloor < 0$ and hence $M < R + 2 - \frac{1}{R}$, RM degrees of freedom can be achieved by zero forcing at each receiver. When $M \geq R + 2$, we provide an achievable scheme based on interference alignment to show that the i^{th} user can achieve d_i degrees of freedom where $R \lfloor \frac{RM}{R^2+2R-1} \rfloor \leq d_i \leq M$ and $d_1 + \dots + d_{R+2} = RM + \lfloor \frac{RM}{R^2+2R-1} \rfloor$.

Transmitter i sends message W_i to Receiver i using d_i independently encoded streams along vectors $\mathbf{v}_m^{[i]}$, i.e.,

$$\mathbf{X}^{[i]} = \sum_{m=1}^{d_i} x_m^i \mathbf{v}_m^{[i]} = \mathbf{V}^{[i]} \mathbf{X}^i \quad i = 1, \dots, R + 2$$

Then, the received signal is

$$\mathbf{Y}^{[j]} = \sum_{i=1}^{R+2} \mathbf{H}^{[ji]} \mathbf{V}^{[i]} \mathbf{X}^i + \mathbf{Z}^{[j]}.$$

In order for each receiver to decode its desired signal streams by zero forcing the interference, the dimension of the interference has to be less than or equal to $RM - d_i$. However, there are $\lfloor \frac{RM}{R^2+2R-1} \rfloor + RM - d_i$ interference vectors at Receiver i . Therefore, we need to align $\lfloor \frac{RM}{R^2+2R-1} \rfloor$ interference signal vectors at each receiver. This can be achieved if $\lfloor \frac{RM}{R^2+2R-1} \rfloor$ interference vectors are aligned within the space spanned by all other interference vectors. First, we write $\mathbf{V}^{[i]}$ in the block matrix form:

$$\mathbf{V}^{[i]} = [\mathbf{V}_1^{[i]} \quad \mathbf{V}_2^{[i]} \quad \dots \quad \mathbf{V}_R^{[i]} \quad \mathbf{V}_{R+1}^{[i]}]$$

where $\mathbf{V}_1^{[i]}, \dots, \mathbf{V}_R^{[i]}$ are $M \times \lfloor \frac{RM}{R^2+2R-1} \rfloor$ dimensional matrices and $\mathbf{V}_{R+1}^{[i]}$ is an $M \times (d_i - R \lfloor \frac{RM}{R^2+2R-1} \rfloor)$ dimensional matrix. At Receiver 1, we align the range of $\mathbf{H}^{[1(R+2)]} \mathbf{V}_1^{[R+2]}$ within the space spanned by other interference vectors:

$$\begin{aligned} \text{span}(\mathbf{H}^{[1(R+2)]} \mathbf{V}_1^{[R+2]}) &\subset \text{span}([\mathbf{H}^{[12]} \mathbf{V}_1^{[2]} \quad \mathbf{H}^{[13]} \mathbf{V}_1^{[3]} \quad \dots \quad \mathbf{H}^{[1(R+1)]} \mathbf{V}_1^{[R+1]}) \\ \Rightarrow \text{span}(\underbrace{[\mathbf{H}^{[12]} \quad \mathbf{H}^{[13]} \quad \dots \quad \mathbf{H}^{[1(R+1)]}]^{-1} \mathbf{H}^{[1(R+2)]}}_{\mathbf{T}^{[1]}} \mathbf{V}_1^{[R+2]}) &\subset \text{span} \left(\begin{bmatrix} \mathbf{V}_1^{[2]} & \mathbf{0} & \dots & \mathbf{0} \\ \mathbf{0} & \mathbf{V}_1^{[3]} & \dots & \mathbf{0} \\ \vdots & \vdots & \ddots & \vdots \\ \mathbf{0} & \mathbf{0} & \dots & \mathbf{V}_1^{[R+1]} \end{bmatrix} \right) \end{aligned} \quad (38)$$

Note that $\mathbf{T}^{[1]}$ is a $RM \times M$ matrix and can be written in a block matrix form:

$$\mathbf{T}^{[1]} = \begin{bmatrix} \mathbf{T}_1^{[1]} \\ \mathbf{T}_2^{[1]} \\ \vdots \\ \mathbf{T}_R^{[1]} \end{bmatrix}$$

Then, condition (38) can be expressed equivalently as

$$\text{span}\left(\begin{bmatrix} \mathbf{T}_1^{[1]} \mathbf{V}_1^{[R+2]} \\ \mathbf{T}_2^{[1]} \mathbf{V}_1^{[R+2]} \\ \vdots \\ \mathbf{T}_R^{[1]} \mathbf{V}_1^{[R+2]} \end{bmatrix}\right) \subset \text{span}\left(\begin{bmatrix} \mathbf{V}^{[2]} & \mathbf{0} & \dots & \mathbf{0} \\ \mathbf{0} & \mathbf{V}^{[3]} & \dots & \mathbf{0} \\ \vdots & \vdots & \ddots & \vdots \\ \mathbf{0} & \mathbf{0} & \dots & \mathbf{V}^{[R+1]} \end{bmatrix}\right)$$

This condition can be satisfied if

$$\begin{aligned} \mathbf{T}_1^{[1]} \mathbf{V}_1^{[R+2]} &= \mathbf{V}_1^{[2]} \\ \mathbf{T}_2^{[1]} \mathbf{V}_1^{[R+2]} &= \mathbf{V}_1^{[3]} \\ &\vdots \\ \mathbf{T}_{R-1}^{[1]} \mathbf{V}_1^{[R+2]} &= \mathbf{V}_1^{[R]} \\ \text{span}(\mathbf{T}_R^{[1]} \mathbf{V}_1^{[R+2]}) &= \text{span}(\mathbf{V}_1^{[R+1]}) \end{aligned} \quad (39)$$

At Receiver 2, we align the range of $\mathbf{H}^{[2(R+2)]} \mathbf{V}_1^{[R+2]}$ within the space spanned by other interference vectors:

$$\text{span}(\mathbf{H}^{[2(R+2)]} \mathbf{V}_1^{[R+2]}) \subset \text{span}([\mathbf{H}^{[21]} \mathbf{V}^{[1]} \quad \mathbf{H}^{[23]} \mathbf{V}^{[3]} \quad \dots \quad \mathbf{H}^{[2(R+1)]} \mathbf{V}^{[R+1]}])$$

By similar arguments used at Receiver 1, this condition can be satisfied if

$$\begin{aligned} \mathbf{T}_1^{[2]} \mathbf{V}_1^{[R+2]} &= \mathbf{V}_1^{[1]} \\ \mathbf{T}_2^{[2]} \mathbf{V}_1^{[R+2]} &= \mathbf{V}_2^{[3]} \\ &\vdots \\ \mathbf{T}_{R-1}^{[2]} \mathbf{V}_1^{[R+2]} &= \mathbf{V}_2^{[R]} \\ \text{span}(\mathbf{T}_R^{[2]} \mathbf{V}_1^{[R+2]}) &= \text{span}(\mathbf{V}_1^{[R+1]}) \end{aligned} \quad (40)$$

where

$$\mathbf{T}^{[2]} = \begin{bmatrix} \mathbf{T}_1^{[2]} \\ \mathbf{T}_2^{[2]} \\ \vdots \\ \mathbf{T}_R^{[2]} \end{bmatrix} = [\mathbf{H}^{[21]} \quad \mathbf{H}^{[23]} \quad \dots \quad \mathbf{H}^{[2(R+1)]}]^{-1} \mathbf{H}^{[2(R+2)]}$$

At Receiver j , $\forall j, 2 < j \leq R + 1$, we align the range of $\mathbf{H}^{[j(j-1)]} \mathbf{V}_1^{[j-1]}$ within the space spanned by other interference vectors:

$$\text{span}(\mathbf{H}^{[j(j-1)]} \mathbf{V}_1^{[j-1]}) \subset \text{span}([\bar{\mathbf{H}}^{[j1]} \mathbf{V}^{[1]} \quad \dots \quad \bar{\mathbf{H}}^{[j(j-2)]} \mathbf{V}^{[j-2]} \quad \bar{\mathbf{H}}^{[j(j+1)]} \mathbf{V}^{[j+1]} \quad \dots \quad \bar{\mathbf{H}}^{[ji]} \mathbf{V}^{[i]} \quad \dots \quad \bar{\mathbf{H}}^{[j(R+2)]} \mathbf{V}^{[R+2]})$$

By similar arguments used at Receiver 1, this condition can be satisfied if

$$\mathbf{T}^{[j]} \mathbf{V}_1^{[j-1]} = \begin{bmatrix} \mathbf{V}_{n(1,j)}^{[1]} \\ \vdots \\ \mathbf{V}_{n(j-2,j)}^{[j-2]} \\ \mathbf{V}_{n(j+1,j)}^{[j+1]} \\ \vdots \\ \mathbf{V}_{n(i,j)}^{[i]} \\ \vdots \\ \mathbf{V}_{n(R+2,j)}^{[R+2]} \end{bmatrix}$$

where

$$\mathbf{T}^{[j]} = [\mathbf{H}^{[j1]} \dots \mathbf{H}^{[j(j-2)]} \mathbf{H}^{[j(j+1)]} \dots \mathbf{H}^{[j(R+2)]}]^{-1} \mathbf{H}^{[j(j-1)]} \quad n(i,j) = \begin{cases} j-1 & i = 1, R+1, R+2, i \neq j \\ j-2 & 1 < i < R+1, j > i+1 \\ j & 3 < i < R+1, j < i \end{cases}$$

At Receiver $R+2$, we align the range of $\mathbf{H}^{[(R+2)1]} \mathbf{V}_1^{[1]}$ within the space spanned by other interference vectors:

$$\text{span}(\mathbf{H}^{[(R+2)1]} \mathbf{V}_1^{[1]}) \subset \text{span}([\mathbf{H}^{[(R+2)2]} \mathbf{V}^{[2]} \mathbf{H}^{[(R+2)3]} \mathbf{V}^{[3]} \dots \mathbf{H}^{[(R+2)(R+1)]} \mathbf{V}^{[R+1]}])$$

This condition can be satisfied if

$$\mathbf{T}^{[R+2]} \mathbf{V}_1^{[1]} = \begin{bmatrix} \mathbf{V}_R^{[2]} \\ \mathbf{V}_R^{[3]} \\ \vdots \\ \mathbf{V}_R^{[R+1]} \end{bmatrix}$$

where

$$\mathbf{T}^{[R+2]} = [\mathbf{H}^{[(R+2)2]} \mathbf{H}^{[(R+2)3]} \dots \mathbf{H}^{[(R+2)(R+1)]}]^{-1} \mathbf{H}^{[(R+2)1]}$$

Notice once $\mathbf{V}_1^{[R+2]}$ is chosen, all other vectors can be solved from the above equations. To solve $\mathbf{V}_1^{[R+2]}$, from (39), (40), we have

$$\begin{aligned} \text{span}(\mathbf{T}_R^{[1]} \mathbf{V}_1^{[R+2]}) &= \text{span}(\mathbf{T}_R^{[2]} \mathbf{V}_1^{[R+2]}) \\ \Rightarrow \text{span}((\mathbf{T}_R^{[2]})^{-1} \mathbf{T}_R^{[1]} \mathbf{V}_1^{[R+2]}) &= \text{span}(\mathbf{V}_1^{[R+2]}) \end{aligned}$$

Hence, columns of $\mathbf{V}_1^{[R+2]}$ can be chosen as

$$\mathbf{V}_1^{[R+2]} = [\mathbf{e}_1 \dots \mathbf{e}_{\lfloor \frac{RM}{R^2+2R-1} \rfloor}] \quad (41)$$

where $\mathbf{e}_1 \dots \mathbf{e}_{\lfloor \frac{RM}{R^2+2R-1} \rfloor}$ are the $\lfloor \frac{RM}{R^2+2R-1} \rfloor$ eigenvectors of $(\mathbf{T}_R^{[2]})^{-1} \mathbf{T}_R^{[1]}$. Note that the above construction only specifies $\mathbf{V}_1^{[i]}, \mathbf{V}_2^{[i]}, \dots, \mathbf{V}_R^{[i]}$. The remaining vectors of $\mathbf{V}_{R+1}^{[i]}$ can be chosen randomly according to a continuous distribution.

Through interference alignment, we ensure that the interference vectors span a small enough signal space. We need to verify that the desired signal vectors, i.e., $\mathbf{H}^{[ii]} \mathbf{V}^{[i]}$ are linearly independent of interference vectors so that each receiver can decode its message using zero forcing. Notice that the direct channel matrices $\mathbf{H}^{[ii]}, i = 1, \dots, R+2$ do not appear in the interference alignment equations, $\mathbf{V}^{[i]}$ undergoes an independent linear transformation by

multiplying $\mathbf{H}^{[ii]}$. Therefore, the desired signal vectors are linearly independent of the interference signals with probability one. As a result, user i can achieve d_i degrees of freedom for a total of $RM + \lfloor \frac{RM}{R^2+2R-1} \rfloor$ degrees of freedom.

B. Proof of Theorem 5

We will provide an achievable scheme based on interference alignment to show in the $\lceil \frac{R+2}{M} \rceil$ symbol extension channel, user $i, \forall i = 1, 3, \dots, R+2$ can achieve d_i ($R \leq d_i \leq \lceil \frac{R+2}{M} \rceil M$) degrees of freedom and user 2 can achieve d_2 ($R+1 \leq d_2 \leq \lceil \frac{R+2}{M} \rceil M$) degrees of freedom for a total of $RM \lceil \frac{R+2}{M} \rceil + 1$ degrees of freedom. Hence, $RM + \frac{1}{\lceil \frac{R+2}{M} \rceil}$ degrees of freedom can be achieved on the original channel. Over the extension channel, the channel input-output relationship is

$$\bar{\mathbf{Y}}^{[j]} = \sum_{i=1}^{R+2} \bar{\mathbf{H}}^{[ji]} \bar{\mathbf{X}}^{[i]} + \bar{\mathbf{Z}}^{[j]}$$

where the overbar notation represents the $\lceil \frac{R+2}{M} \rceil$ -symbol extensions so that

$$\bar{\mathbf{X}} \triangleq \begin{bmatrix} \mathbf{X}(\lceil \frac{R+2}{M} \rceil t) \\ \vdots \\ \mathbf{X}(\lceil \frac{R+2}{M} \rceil (t+1) - 1) \end{bmatrix} \quad \bar{\mathbf{Z}} \triangleq \begin{bmatrix} \mathbf{Z}(\lceil \frac{R+2}{M} \rceil t) \\ \vdots \\ \mathbf{Z}(\lceil \frac{R+2}{M} \rceil (t+1) - 1) \end{bmatrix}$$

where \mathbf{X} and \mathbf{Z} are $M \times 1$ and $RM \times 1$ vectors respectively, and

$$\bar{\mathbf{H}} \triangleq \begin{bmatrix} \mathbf{H} & \mathbf{0} & \cdots & \mathbf{0} \\ \mathbf{0} & \mathbf{H} & \cdots & \mathbf{0} \\ \vdots & \vdots & \ddots & \vdots \\ \mathbf{0} & \mathbf{0} & \cdots & \mathbf{H} \end{bmatrix}.$$

where \mathbf{H} is the $RM \times M$ channel matrix.

In the extension channel, Transmitter i sends message W_i to Receiver i using d_i independently encoded streams along vectors $\bar{\mathbf{v}}_1^{[i]}, \dots, \bar{\mathbf{v}}_{d_i}^{[i]}$, i.e.,

$$\bar{\mathbf{X}}^{[i]} = \sum_{m=1}^{d_i} \bar{\mathbf{v}}_m^{[i]} x_m^{[i]} = \bar{\mathbf{V}}^{[i]} \mathbf{X}^{[i]}$$

where $\bar{\mathbf{V}}^{[i]}$ and $\mathbf{X}^{[i]}$ are $M \lceil \frac{R+2}{M} \rceil \times d_i$ and $d_i \times 1$ matrices respectively. In order for each receiver to decode its desired signal streams by zero forcing the interference, the dimension of the space spanned by the interference vectors has to be less than or equal to $RM \lceil \frac{R+2}{M} \rceil - d_i$. However, there are $RM \lceil \frac{R+2}{M} \rceil - d_i + 1$ interference vectors at Receiver i . Therefore, we need to align 1 interference signal vector at each receiver. This can be achieved if one interference vector is aligned within the space spanned by all other interference vectors. Mathematically, we choose the following interference alignment equations:

At Receiver 1:

$$\begin{aligned} \text{span}(\bar{\mathbf{H}}^{[12]} \bar{\mathbf{v}}_1^{[2]}) &\subset \text{span}(\bar{\mathbf{H}}^{[13]} \bar{\mathbf{V}}^{[3]} \quad \bar{\mathbf{H}}^{[14]} \bar{\mathbf{V}}^{[4]} \quad \dots \quad \bar{\mathbf{H}}^{[1(R+1)]} \bar{\mathbf{V}}^{[R+1]}) \\ \Rightarrow \text{span}(\underbrace{[\bar{\mathbf{H}}^{[13]} \quad \bar{\mathbf{H}}^{[14]} \quad \dots \quad \bar{\mathbf{H}}^{[1(R+1)]}]^{-1} \bar{\mathbf{H}}^{[12]}}_{\mathbf{T}^{[1]}} \bar{\mathbf{v}}_1^{[2]}) &\subset \text{span} \left(\begin{bmatrix} \bar{\mathbf{V}}^{[3]} & \mathbf{0} & \cdots & \mathbf{0} \\ \mathbf{0} & \bar{\mathbf{V}}^{[4]} & \cdots & \mathbf{0} \\ \vdots & \vdots & \ddots & \vdots \\ \mathbf{0} & \mathbf{0} & \cdots & \bar{\mathbf{V}}^{[R+1]} \end{bmatrix} \right) \end{aligned}$$

This can be achieved if

$$\mathbf{T}^{[1]}\bar{\mathbf{v}}_1^{[2]} = \begin{bmatrix} \bar{\mathbf{v}}_1^{[3]} \\ \bar{\mathbf{v}}_1^{[4]} \\ \vdots \\ \bar{\mathbf{v}}_1^{[R+1]} \end{bmatrix} \quad (42)$$

At Receiver j , $\forall j \ 2 \leq j \leq R+1$:

$$\begin{aligned} \text{span}(\bar{\mathbf{H}}^{[j(j+1)]}\bar{\mathbf{v}}_1^{[j+1]}) &\subset \text{span}([\bar{\mathbf{H}}^{[j1]}\bar{\mathbf{V}}^{[1]} \ \dots \ \bar{\mathbf{H}}^{[j(j-1)]}\bar{\mathbf{V}}^{[j-1]} \ \bar{\mathbf{H}}^{[j(j+2)]}\bar{\mathbf{V}}^{[j+2]} \ \dots \ \bar{\mathbf{H}}^{[j(R+2)]}\bar{\mathbf{V}}^{[R+2]}) \\ &\Rightarrow \text{span}(\underbrace{[\bar{\mathbf{H}}^{[j1]} \ \dots \ \bar{\mathbf{H}}^{[j(j-1)}] \ \bar{\mathbf{H}}^{[j(j+2)}] \ \dots \ \bar{\mathbf{H}}^{[j(R+2)}]}_{\mathbf{T}^{[j]}}]^{-1}\bar{\mathbf{H}}^{[j(j+1)]}\bar{\mathbf{v}}_1^{[j+1]}) \subset \\ &\text{span}\left(\begin{bmatrix} \bar{\mathbf{v}}^{[1]} & \mathbf{0} & \dots & \mathbf{0} & \mathbf{0} & \dots & \mathbf{0} \\ \mathbf{0} & \bar{\mathbf{v}}^{[2]} & \dots & \mathbf{0} & \mathbf{0} & \dots & \mathbf{0} \\ \vdots & \vdots & \ddots & \vdots & \vdots & \ddots & \vdots \\ \mathbf{0} & \mathbf{0} & \dots & \bar{\mathbf{v}}^{[j-1]} & \dots & \dots & \mathbf{0} \\ \mathbf{0} & \mathbf{0} & \dots & \dots & \bar{\mathbf{v}}^{[j+2]} & \dots & \mathbf{0} \\ \vdots & \vdots & \vdots & \vdots & \vdots & \ddots & \vdots \\ \mathbf{0} & \mathbf{0} & \dots & \mathbf{0} & \mathbf{0} & \dots & \bar{\mathbf{v}}^{[R+2]} \end{bmatrix} \right) \end{aligned}$$

This condition can be satisfied if

$$\mathbf{T}^{[j]}\bar{\mathbf{v}}_1^{[j+1]} = \begin{bmatrix} \bar{\mathbf{v}}_{n(1,j)}^{[1]} \\ \vdots \\ \bar{\mathbf{v}}_{n(j-1,j)}^{[j-1]} \\ \bar{\mathbf{v}}_{n(j+2,j)}^{[j+2]} \\ \vdots \\ \bar{\mathbf{v}}_{n(i,j)}^{[j]} \\ \vdots \\ \bar{\mathbf{v}}_{n(R+2,j)}^{[R+2]} \end{bmatrix} \quad (43)$$

where

$$n(i, j) = \begin{cases} j-1 & i = 1, 2, j > i \\ j & i \geq 3, j < i-1 \\ j-2 & i \geq 3, j \geq i+1 \end{cases}$$

At Receiver $R+2$:

$$\begin{aligned} \text{span}(\bar{\mathbf{H}}^{[(R+2)1]}\bar{\mathbf{v}}_1^{[1]}) &\subset \text{span}([\bar{\mathbf{H}}^{[(R+2)2]}\bar{\mathbf{V}}^{[2]} \ \bar{\mathbf{H}}^{[(R+2)3]}\bar{\mathbf{V}}^{[3]} \ \dots \ \bar{\mathbf{H}}^{[(R+2)(R+1)]}\bar{\mathbf{V}}^{[R+1]}) \\ &\Rightarrow \text{span}(\underbrace{[\bar{\mathbf{H}}^{[(R+2)2]} \ \bar{\mathbf{H}}^{[(R+2)3]} \ \dots \ \bar{\mathbf{H}}^{[(R+2)(R+1)}]}_{\mathbf{T}^{[R+2]}}]^{-1}\bar{\mathbf{H}}^{[(R+2)1]}\bar{\mathbf{v}}_1^{[1]}) \subset \text{span}\left(\begin{bmatrix} \bar{\mathbf{V}}^{[2]} & \mathbf{0} & \dots & \mathbf{0} \\ \mathbf{0} & \bar{\mathbf{V}}^{[3]} & \dots & \mathbf{0} \\ \vdots & \vdots & \ddots & \vdots \\ \mathbf{0} & \mathbf{0} & \dots & \bar{\mathbf{V}}^{[R+1]} \end{bmatrix} \right) \end{aligned}$$

This can be achieved if

$$\mathbf{T}^{[R+2]}\bar{\mathbf{v}}_1^{[1]} = \begin{bmatrix} \bar{\mathbf{v}}_{R+1}^{[2]} \\ \bar{\mathbf{v}}_R^{[3]} \\ \vdots \\ \bar{\mathbf{v}}_R^{[R+1]} \end{bmatrix} \quad (44)$$

Note that once we pick $\bar{\mathbf{v}}_1^{[2]}$, all other vectors can be solved from (42), (43), (44). $\bar{\mathbf{v}}_1^{[2]}$ can be chosen randomly according to a continuous distribution as long as no entry of $\bar{\mathbf{v}}_1^{[2]}$ is equal to zero. Note that the above construction only specifies $\bar{\mathbf{v}}_1^{[i]}, \dots, \bar{\mathbf{v}}_R^{[i]}, \forall i = 1, 2, \dots, R+2$ and $\bar{\mathbf{v}}_{R+1}^{[2]}$. The remaining $\bar{\mathbf{v}}_{R+1}^{[i]}, \dots, \bar{\mathbf{v}}_{d_i}^{[i]}, \forall i = 1, 3, \dots, R+2$ and $\bar{\mathbf{v}}_{R+2}^{[2]}, \dots, \bar{\mathbf{v}}_{d_2}^{[2]}$ can be chosen randomly from a continuous distribution. Since all the vectors are chosen independently of the direct channel matrices $\bar{\mathbf{H}}^{[i]}$ and all entries of $\bar{\mathbf{V}}^{[i]}$ are not equal to zero almost surely, the desired signal vectors are linearly independent of the interference vectors at each receiver. As a result, each receiver can decode its message by zero forcing the interference to achieve d_i degrees of freedom for a total of $RM \lceil \frac{R+2}{M} \rceil + 1$ degrees of freedom on the $\lceil \frac{R+2}{M} \rceil$ -symbol extension channel. Therefore, $RM + \frac{1}{\lceil \frac{R+2}{M} \rceil}$ degrees of freedom per channel use can be achieved on the original channel.

REFERENCES

- [1] A.B. Carleial, "A case where interference does not reduce capacity," *IEEE Trans. Inform. Theory*, vol. 21, pp. 569–570, Sep. 1975.
- [2] H. Sato, "The capacity of the Gaussian interference channel under strong interference," *IEEE Trans. Inform. Theory*, vol. 27, pp. 786–788, Nov. 1981.
- [3] T.S. Han and K. Kobayashi, "A new achievable rate region for the interference channel," *IEEE Trans. Inform. Theory*, vol. 27, pp. 49–60, Jan. 1981.
- [4] M.H.M. Costa, "On the Gaussian interference channel," *IEEE Trans. Inform. Theory*, vol. 31, pp. 607–615, Sept. 1985.
- [5] H. Sato, "Two-user communication channels," *IEEE Trans. Inform. Theory*, vol. 23, pp. 295–304, May 1977.
- [6] A.B. Carleial, "Outer bounds on the capacity of interference channels," *IEEE Trans. Inform. Theory*, vol. 29, pp. 602–606, July 1983.
- [7] G. Kramer, "Outer bounds on the capacity of Gaussian interference channels," *IEEE Trans. on Inform. Theory*, vol. 50, pp. 581–586, Mar. 2004.
- [8] R. H. Etkin, D. N. C. Tse, and H. Wang, "Gaussian interference channel capacity to within one bit," *submitted to the IEEE Trans. Inform. Theory*, 2007.
- [9] E. Telatar and D. Tse, "Bounds on the capacity region of a class of interference channels," in *Proc. IEEE International Symposium on Information Theory 2007*, Nice, France, Jun. 2007.
- [10] X. Shang, G. Kramer, and B. Chen, "New Outer Bounds on the Capacity Region of Gaussian Interference Channels," *Proc. IEEE International Symposium on Information Theory 2008*, Toronto, ON, Canada, July, 2008
- [11] S. Vishwanath and S. Jafar, "On the Capacity of Vector Gaussian Interference Channels," *IEEE ITW*, 2004.
- [12] X. Shang, B. Chen, G. Kramer, and H. V. Poor, "On the Capacity of MIMO Interference Channels," <http://arxiv.org/abs/0807.1543>, 2008.
- [13] E. A. Jorswieck, E. G. Larsson and D. Danev, "Complete Characterization of the Pareto Boundary for the MISO Interference Channel," in *Proc. IEEE Trans. on Signal Processing*, Aug. 2008.
- [14] A. Host-Madsen and A. Nosratinia, "The multiplexing gain of wireless networks," in *Proc. of ISIT*, 2005.
- [15] S. Jafar and M. Fakhereddin, "Degrees of freedom for the MIMO interference channel," in *Proc. of ISIT*, 2006.
- [16] V. R. Cadambe and S. A. Jafar, "Interference Alignment and Degrees of Freedom of the K -User Interference Channel," *IEEE Trans. on Inform. Theory*, vol. 54, No.8, August 2008.
- [17] S. Jafar and S. Shamai, "Degrees of freedom region for the mimo X channel," *IEEE Trans. on Information Theory*, vol. 54, pp. 151–170, Jan. 2008.
- [18] V. R. Cadambe and S. A. Jafar, "Degrees of freedom of wireless X networks," arxiv.org, 2007. arxiv eprint = cs/0711.2824.
- [19] K. Gomadam, V. Cadambe and S. Jafar, "Approaching the Capacity of Wireless Networks through Distributed Interference Alignment," *Preprint available through <http://newport.eecs.uci.edu/syed>*, March 2008.

- [20] V. Cadambe, S. Jafar, and S. Shamai, "Interference alignment on the deterministic channel and application to gaussian networks," arXiv:0711.2547.